

Programmable Controller

MELSEC iQ-R
series

MELSEC iQ-R AnyWireASLINK Master Module User's Manual (Application)

-RJ51AW12AL

Powered by

Anywire

This product was jointly developed and manufactured by Mitsubishi and Anywire Corporation.

*Note that the warranty on this product differs from that on other programmable controller products.
(Refer to "WARRANTY" in this manual.)

AnyWireASLINK

COPYRIGHT

This document is protected by the law of copyright, whereby all rights established therein remain with the company Mitsubishi Electric Corporation. Reproduction of this document or parts of this document is only permissible within the limits of the legal determination of Copyright Law. Alteration or abridgement of the document is not permitted without the explicit written approval of the company Mitsubishi Electric Corporation.

PRECAUTIONS REGARDING WARRANTY AND SPECIFICATIONS

The RJ51AW12AL was jointly developed and manufactured by Mitsubishi and Anywire Corporation. Note that there are differences in warranty.

- Warranty

Item	RJ51AW12AL	Other programmable controller products (e.g. MELSEC iQ-R series)
Repair term after discontinuation of production	1 year	7 years

- Application of the EMC Directive

Item	RJ51AW12AL	Other programmable controller products (e.g. MELSEC iQ-R series)
Applicable EMC standard	EN61131-2	EN61131-2

- Application of the UL/cUL standards

Item	RJ51AW12AL	Other programmable controller products (e.g. MELSEC iQ-R series)
Applicable UL standard/cUL standard	UL508 CSA22.2	UL508 CSA22.2

SAFETY PRECAUTIONS

(Read these precautions before using this product.)

Before using this product, please read this manual and the relevant manuals carefully and pay full attention to safety to handle the product correctly.

The precautions given in this manual are concerned with this product only. For the safety precautions of the programmable controller system, refer to the MELSEC iQ-R Module Configuration Manual.

In this manual, the safety precautions are classified into two levels: "⚠ WARNING" and "⚠ CAUTION".



WARNING

Indicates that incorrect handling may cause hazardous conditions, resulting in death or severe injury.



CAUTION

Indicates that incorrect handling may cause hazardous conditions, resulting in minor or moderate injury or property damage.

Under some circumstances, failure to observe the precautions given under "⚠ CAUTION" may lead to serious consequences.

Observe the precautions of both levels because they are important for personal and system safety.

Make sure that the end users read this manual and then keep the manual in a safe place for future reference.

[Design Precautions]

WARNING

- Configure safety circuits external to the programmable controller to ensure that the entire system operates safely even when a fault occurs in the external power supply or the programmable controller. Failure to do so may result in an accident due to an incorrect output or malfunction.
 - (1) Emergency stop circuits, protection circuits, and protective interlock circuits for conflicting operations (such as forward/reverse rotations or upper/lower limit positioning) must be configured external to the programmable controller.
 - (2) When the programmable controller detects an abnormal condition, it stops the operation and all outputs are:
 - Turned off if the overcurrent or overvoltage protection of the power supply module is activated.
 - Held or turned off according to the parameter setting if the self-diagnostic function of the CPU module detects an error such as a watchdog timer error.
 - (3) All outputs may be turned on if an error occurs in a part, such as an I/O control part, where the CPU module cannot detect any error. To ensure safety operation in such a case, provide a safety mechanism or a fail-safe circuit external to the programmable controller. For a fail-safe circuit example, refer to "General Safety Requirements" in the MELSEC iQ-R Module Configuration Manual.
 - (4) Outputs may remain on or off due to a failure of a component such as a relay and transistor in an output circuit. Configure an external circuit for monitoring output signals that could cause a serious accident.
 - In an output circuit, when a load current exceeding the rated current or an overcurrent caused by a load short-circuit flows for a long time, it may cause smoke and fire. To prevent this, configure an external safety circuit, such as a fuse.
 - For the operating status of each station after a communication failure, refer to manuals relevant to the network. Incorrect output or malfunction due to a communication failure may result in an accident.
 - When connecting an external device with a CPU module or intelligent function module to modify data of a running programmable controller, configure an interlock circuit in the program to ensure that the entire system will always operate safely. For other forms of control (such as program modification, parameter change, forced output, or operating status change) of a running programmable controller, read the relevant manuals carefully and ensure that the operation is safe before proceeding. Improper operation may damage machines or cause accidents.
-

[Design Precautions]

WARNING

- Especially, when a remote programmable controller is controlled by an external device, immediate action cannot be taken if a problem occurs in the programmable controller due to a communication failure. To prevent this, configure an interlock circuit in the program, and determine corrective actions to be taken between the external device and CPU module in case of a communication failure.
 - Do not write any data to the "system area" and "write-protect area" of the buffer memory in the module. Also, do not use any "use prohibited" signals as an output signal from the CPU module to each module. Doing so may cause malfunction of the programmable controller system. For the "system area", "write-protect area", and the "use prohibited" signals, refer to the user's manual for the module used.
 - If a communication cable is disconnected, the network may be unstable, resulting in a communication failure of multiple stations. Configure an interlock circuit in the program to ensure that the entire system will always operate safely even if communications fail. Failure to do so may result in an accident due to an incorrect output or malfunction.
 - To maintain the safety of the programmable controller system against unauthorized access from external devices via the network, take appropriate measures. To maintain the safety against unauthorized access via the Internet, take measures such as installing a firewall.
 - An AnyWireASLINK system has no control function for ensuring safety.
-

[Design Precautions]

CAUTION

- Do not install the control lines or communication cables together with the main circuit lines or power cables. Keep a distance of 100mm or more between them. Failure to do so may result in malfunction due to noise.
 - During control of an inductive load such as a lamp, heater, or solenoid valve, a large current (approximately ten times greater than normal) may flow when the output is turned from off to on. Therefore, use a module that has a sufficient current rating.
 - After the CPU module is powered on or is reset, the time taken to enter the RUN status varies depending on the system configuration, parameter settings, and/or program size. Design circuits so that the entire system will always operate safely, regardless of the time.
 - Do not power off the programmable controller or reset the CPU module while the settings are being written.
Doing so will make the data in the flash ROM and SD memory card undefined. The values need to be set in the buffer memory and written to the flash ROM and SD memory card again. Doing so also may cause malfunction or failure of the module.
 - When changing the operating status of the CPU module from external devices (such as the remote RUN/STOP functions), select "Do Not OPEN in Program" for "Open Method Setting" of "Module Parameter". If "OPEN in Program" is selected, an execution of the remote STOP function causes the communication line to close. Consequently, the CPU module cannot reopen the line, and external devices cannot execute the remote RUN function.
-

[Installation Precautions]

WARNING

- Shut off the external power supply (all phases) used in the system before mounting or removing the module. Failure to do so may result in electric shock or cause the module to fail or malfunction.
-

[Installation Precautions]

CAUTION

- Use the programmable controller in an environment that meets the general specifications in the Safety Guidelines included with the base unit. Failure to do so may result in electric shock, fire, malfunction, or damage to or deterioration of the product.
 - To mount a module, place the concave part(s) located at the bottom onto the guide(s) of the base unit, and push in the module until the hook(s) located at the top snaps into place. Incorrect interconnection may cause malfunction, failure, or drop of the module.
 - To mount a module with no module fixing hook, place the concave part(s) located at the bottom onto the guide(s) of the base unit, push in the module, and fix it with screw(s). Incorrect interconnection may cause malfunction, failure, or drop of the module.
 - When using the programmable controller in an environment of frequent vibrations, fix the module with a screw.
 - Tighten the screws within the specified torque range. Undertightening can cause drop of the screw, short circuit, or malfunction. Overtightening can damage the screw and/or module, resulting in drop, short circuit, or malfunction.
 - When using an extension cable, connect it to the extension cable connector of the base unit securely. Check the connection for looseness. Poor contact may cause malfunction.
 - When using an SD memory card, fully insert it into the SD memory card slot. Check that it is inserted completely. Poor contact may cause malfunction.
 - Securely insert an extended SRAM cassette or a battery-less option cassette into the cassette connector of the CPU module. After insertion, close the cassette cover and check that the cassette is inserted completely. Poor contact may cause malfunction.
 - Do not directly touch any conductive parts and electronic components of the module, SD memory card, extended SRAM cassette, battery-less option cassette, or connector. Doing so can cause malfunction or failure of the module.
-

[Wiring Precautions]

WARNING

- Shut off the external power supply (all phases) used in the system before installation and wiring. Failure to do so may result in electric shock or cause the module to fail or malfunction.
 - After installation and wiring, attach a blank cover module (RG60) to each empty slot and an included extension connector protective cover to the unused extension cable connector before powering on the system for operation. Failure to do so may result in electric shock.
-

[Wiring Precautions]

CAUTION

- Individually ground the FG and LG terminals of the programmable controller with a ground resistance of 100 ohms or less. Failure to do so may result in electric shock or malfunction.
 - Use applicable solderless terminals and tighten them within the specified torque range. If any spade solderless terminal is used, it may be disconnected when the terminal screw comes loose, resulting in failure.
 - Check the rated voltage and signal layout before wiring to the module, and connect the cables correctly. Connecting a power supply with a different voltage rating or incorrect wiring may cause fire or failure.
 - Connectors for external devices must be crimped or pressed with the tool specified by the manufacturer, or must be correctly soldered. Incomplete connections may cause short circuit, fire, or malfunction.
 - Securely connect the connector to the module. Poor contact may cause malfunction.
 - Do not install the control lines or communication cables together with the main circuit lines or power cables. Keep a distance of 100mm or more between them. Failure to do so may result in malfunction due to noise.
 - Place the cables in a duct or clamp them. If not, dangling cable may swing or inadvertently be pulled, resulting in damage to the module or cables or malfunction due to poor contact. Do not clamp the extension cables with the jacket stripped. Doing so may change the characteristics of the cables, resulting in malfunction.
 - Check the interface type and correctly connect the cable. Incorrect wiring (connecting the cable to an incorrect interface) may cause failure of the module and external device.
 - Tighten the terminal screws or connector screws within the specified torque range. Undertightening can cause drop of the screw, short circuit, fire, or malfunction. Overtightening can damage the screw and/or module, resulting in drop, short circuit, fire, or malfunction.
-

[Wiring Precautions]

CAUTION

- When disconnecting the cable from the module, do not pull the cable by the cable part. For the cable with connector, hold the connector part of the cable. For the cable connected to the terminal block, loosen the terminal screw. Pulling the cable connected to the module may result in malfunction or damage to the module or cable.
 - Prevent foreign matter such as dust or wire chips from entering the module. Such foreign matter can cause a fire, failure, or malfunction.
 - A protective film is attached to the top of the module to prevent foreign matter, such as wire chips, from entering the module during wiring. Do not remove the film during wiring. Remove it for heat dissipation before system operation.
 - Programmable controllers must be installed in control panels. Connect the main power supply to the power supply module in the control panel through a relay terminal block. Wiring and replacement of a power supply module must be performed by qualified maintenance personnel with knowledge of protection against electric shock. For wiring, refer to the MELSEC iQ-R Module Configuration Manual.
 - For Ethernet cables to be used in the system, select the ones that meet the specifications in the user's manual for the module used. If not, normal data transmission is not guaranteed.
 - Do not apply the 24VDC power before wiring the entire AnyWireASLINK system. If the power is applied before wiring, normal data transmission is not guaranteed.
 - Connect a 24VDC external power supply to the device(s) in an AnyWireASLINK system.
-

[Startup and Maintenance Precautions]

WARNING

- Do not touch any terminal while power is on. Doing so will cause electric shock or malfunction.
 - Correctly connect the battery connector. Do not charge, disassemble, heat, short-circuit, solder, or throw the battery into the fire. Also, do not expose it to liquid or strong shock. Doing so will cause the battery to produce heat, explode, ignite, or leak, resulting in injury and fire.
 - Shut off the external power supply (all phases) used in the system before cleaning the module or retightening the terminal screws, connector screws, or module fixing screws. Failure to do so may result in electric shock.
-

[Startup and Maintenance Precautions]

CAUTION

- When connecting an external device with a CPU module or intelligent function module to modify data of a running programmable controller, configure an interlock circuit in the program to ensure that the entire system will always operate safely. For other forms of control (such as program modification, parameter change, forced output, or operating status change) of a running programmable controller, read the relevant manuals carefully and ensure that the operation is safe before proceeding. Improper operation may damage machines or cause accidents.
 - Especially, when a remote programmable controller is controlled by an external device, immediate action cannot be taken if a problem occurs in the programmable controller due to a communication failure. To prevent this, configure an interlock circuit in the program, and determine corrective actions to be taken between the external device and CPU module in case of a communication failure.
 - Do not disassemble or modify the modules. Doing so may cause failure, malfunction, injury, or a fire.
 - Use any radio communication device such as a cellular phone or PHS (Personal Handy-phone System) more than 25cm away in all directions from the programmable controller. Failure to do so may cause malfunction.
 - Shut off the external power supply (all phases) used in the system before mounting or removing the module. Failure to do so may cause the module to fail or malfunction.
 - Tighten the screws within the specified torque range. Undertightening can cause drop of the component or wire, short circuit, or malfunction. Overtightening can damage the screw and/or module, resulting in drop, short circuit, or malfunction.
 - After the first use of the product, do not perform each of the following operations more than 50 times (IEC 61131-2/JIS B 3502 compliant).
Exceeding the limit may cause malfunction.
 - Mounting/removing the module to/from the base unit
 - Inserting/removing the extended SRAM cassette or battery-less option cassette to/from the CPU module
 - Mounting/removing the terminal block to/from the module
 - After the first use of the product, do not insert/remove the SD memory card to/from the CPU module more than 500 times. Exceeding the limit may cause malfunction.
 - Do not touch the metal terminals on the back side of the SD memory card. Doing so may cause malfunction or failure of the module.
 - Do not touch the integrated circuits on the circuit board of an extended SRAM cassette or a battery-less option cassette. Doing so may cause malfunction or failure of the module.
 - Do not drop or apply shock to the battery to be installed in the module. Doing so may damage the battery, causing the battery fluid to leak inside the battery. If the battery is dropped or any shock is applied to it, dispose of it without using.
 - Startup and maintenance of a control panel must be performed by qualified maintenance personnel with knowledge of protection against electric shock. Lock the control panel so that only qualified maintenance personnel can operate it.
 - Before handling the module, touch a conducting object such as a grounded metal to discharge the static electricity from the human body. Failure to do so may cause the module to fail or malfunction.
-

[Operating Precautions]

CAUTION

- When changing data and operating status, and modifying program of the running programmable controller from an external device such as a personal computer connected to an intelligent function module, read relevant manuals carefully and ensure the safety before operation. Incorrect change or modification may cause system malfunction, damage to the machines, or accidents.
 - Do not power off the programmable controller or reset the CPU module while the setting values in the buffer memory are being written to the flash ROM in the module. Doing so will make the data in the flash ROM and SD memory card undefined. The values need to be set in the buffer memory and written to the flash ROM and SD memory card again. Doing so can cause malfunction or failure of the module.
-

[Disposal Precautions]

CAUTION

- When disposing of this product, treat it as industrial waste.
 - When disposing of batteries, separate them from other wastes according to the local regulations. For details on battery regulations in EU member states, refer to the MELSEC iQ-R Module Configuration Manual.
-

[Transportation Precautions]

CAUTION

- When transporting lithium batteries, follow the transportation regulations. For details on the regulated models, refer to the MELSEC iQ-R Module Configuration Manual.
 - The halogens (such as fluorine, chlorine, bromine, and iodine), which are contained in a fumigant used for disinfection and pest control of wood packaging materials, may cause failure of the product. Prevent the entry of fumigant residues into the product or consider other methods (such as heat treatment) instead of fumigation. The disinfection and pest control measures must be applied to unprocessed raw wood.
-

CONDITIONS OF USE FOR THE PRODUCT

- (1) Mitsubishi programmable controller ("the PRODUCT") shall be used in conditions;
- i) where any problem, fault or failure occurring in the PRODUCT, if any, shall not lead to any major or serious accident; and
 - ii) where the backup and fail-safe function are systematically or automatically provided outside of the PRODUCT for the case of any problem, fault or failure occurring in the PRODUCT.
- (2) The PRODUCT has been designed and manufactured for the purpose of being used in general industries. MITSUBISHI SHALL HAVE NO RESPONSIBILITY OR LIABILITY (INCLUDING, BUT NOT LIMITED TO ANY AND ALL RESPONSIBILITY OR LIABILITY BASED ON CONTRACT, WARRANTY, TORT, PRODUCT LIABILITY) FOR ANY INJURY OR DEATH TO PERSONS OR LOSS OR DAMAGE TO PROPERTY CAUSED BY the PRODUCT THAT ARE OPERATED OR USED IN APPLICATION NOT INTENDED OR EXCLUDED BY INSTRUCTIONS, PRECAUTIONS, OR WARNING CONTAINED IN MITSUBISHI'S USER, INSTRUCTION AND/OR SAFETY MANUALS, TECHNICAL BULLETINS AND GUIDELINES FOR the PRODUCT.

("Prohibited Application")

Prohibited Applications include, but not limited to, the use of the PRODUCT in;

- Nuclear Power Plants and any other power plants operated by Power companies, and/or any other cases in which the public could be affected if any problem or fault occurs in the PRODUCT.
- Railway companies or Public service purposes, and/or any other cases in which establishment of a special quality assurance system is required by the Purchaser or End User.
- Aircraft or Aerospace, Medical applications, Train equipment, transport equipment such as Elevator and Escalator, Incineration and Fuel devices, Vehicles, Manned transportation, Equipment for Recreation and Amusement, and Safety devices, handling of Nuclear or Hazardous Materials or Chemicals, Mining and Drilling, and/or other applications where there is a significant risk of injury to the public or property.

Notwithstanding the above restrictions, Mitsubishi may in its sole discretion, authorize use of the PRODUCT in one or more of the Prohibited Applications, provided that the usage of the PRODUCT is limited only for the specific applications agreed to by Mitsubishi and provided further that no special quality assurance or fail-safe, redundant or other safety features which exceed the general specifications of the PRODUCTS are required. For details, please contact the Mitsubishi representative in your region.

INTRODUCTION

Thank you for purchasing the Mitsubishi Electric MELSEC iQ-R series programmable controllers.

This manual describes the functions, programming, and troubleshooting of the relevant product listed below.

Before using this product, please read this manual and the relevant manuals carefully and develop familiarity with the functions and performance of the MELSEC iQ-R series programmable controller to handle the product correctly.

When applying the program examples provided in this manual to an actual system, ensure the applicability and confirm that it will not cause system control problems.

Please make sure that the end users read this manual.

This module was jointly developed by Mitsubishi and Anywire Corporation. The module allows the AnyWireASLINK[®] system to be connected to a MELSEC iQ-R series programmable controller system.

Relevant product

RJ51AW12AL

CONTENTS

COPYRIGHT	1
PRECAUTIONS REGARDING WARRANTY AND SPECIFICATIONS	1
SAFETY PRECAUTIONS	2
CONDITIONS OF USE FOR THE PRODUCT	10
INTRODUCTION	10
RELEVANT MANUALS	13
TERMS	14
GENERIC TERMS AND ABBREVIATION	15
CHAPTER 1 FUNCTIONS	16
1.1 AnyWireASLINK Transmission	16
Bit transmission	17
Word transmission	17
1.2 Double Verification	19
1.3 Remote Address Change Function	20
1.4 Same ID Used Detection Function	21
1.5 Module with No ID Setting Detection Function	23
1.6 Transmission Cable Short Detection Function	25
1.7 Disconnected Transmission Cable Location Detection Function	26
1.8 Transmission Cable Voltage Drop Detection Function	28
1.9 Parameter Access Error Detection Function	29
1.10 Error Status Automatic Recovery Function	31
1.11 Slave Module Information Acquisition at Start-up Function	32
1.12 Slave Module Parameter Read/Write	33
1.13 Easy Replacement function for One Slave Module	41
1.14 Word Data Start Address Setting Function	44
1.15 AnyWireASLINK Version Compatibility Inspection Function	45
CHAPTER 2 PARAMETER SETTINGS	48
2.1 Parameter Setting Procedure	48
2.2 Basic Setting	49
Bit data setting	49
Startup operating mode setting	49
Bit data double verification setting	50
Error status automatic recovery setting	50
Holding/clearing output data against error setting	50
Holding/clearing word output data against error setting	50
Enabling/disabling the easy replacement setting for one slave module	51
Word data point setting	51
2.3 Refresh Setting	52
2.4 Refresh Processing Time	53
When the refresh target is a module label or refresh data register (RD)	53
When the refresh target is a specified device	53
2.5 Slave Module Address Setting	54
2.6 Automatic Address Detection Function	58
Executing the automatic address detection	58
Automatic address detection execution timing	60
2.7 Automatic reading of system configuration	61

CHAPTER 3 PROGRAMMING	62
3.1 Precautions on Programming	62
3.2 Communication Example When the Slave Module is Added or Deleted	63
System configuration example	63
Setting in the RJ51AW12AL	66
Settings in the slave modules	68
Checking the system status	68
Program example	69
CHAPTER 4 TROUBLESHOOTING	73
4.1 Checking with LED	73
4.2 Checking Module Status	75
Checking with the "Module Diagnostics" window	75
Checking with the buffer memory	76
4.3 Troubleshooting by Symptom	77
4.4 List of Error Codes	80
4.5 Event List	84
APPENDICES	86
Appendix 1 Module Label	86
Appendix 2 I/O Signals	87
List of I/O signals	87
Details of the input signal	89
Details of the output signal	93
Appendix 3 Buffer Memory	94
List of buffer memory addresses	94
Details of buffer memory addresses	96
Appendix 4 Processing Time	111
Transmission cycle time	111
Bit data update timing	118
Update timing of word data	119
Response delay time	120
Parameter access response time	122
Appendix 5 When Connecting the Module to a Remote Head Module	123
Restricted functions and specifications	123
Communication example	123
Appendix 6 Added or Changed Functions	133
INDEX	134
REVISIONS	136
WARRANTY	137
TRADEMARKS	138

RELEVANT MANUALS

Manual name [manual number]	Description	Available form
MELSEC iQ-R AnyWireASLINK Master Module User's Manual (Application) [SH-081585ENG] (this manual)	Functions, parameter settings, programming, troubleshooting, I/O signals, and buffer memory of the AnyWireASLINK master module	Print book e-Manual PDF
MELSEC iQ-R AnyWireASLINK Master Module User's Manual (Startup) [SH-081584ENG]	Specifications, procedures before operation, system configuration, wiring, and communication examples of the AnyWireASLINK master module	Print book e-Manual PDF
iQ Sensor Solution Reference Manual [SH-081133ENG]	Operation methods of the online function with iQ Sensor Solution	Print book e-Manual PDF



e-Manual refers to the Mitsubishi FA electronic book manuals that can be browsed using a dedicated tool.

e-Manual has the following features:

- Required information can be cross-searched in multiple manuals.
- Other manuals can be accessed from the links in the manual.
- The hardware specifications of each part can be found from the product figures.
- Pages that users often browse can be bookmarked.
- Sample programs can be copied to an engineering tool.

TERMS

Unless otherwise specified, this manual uses the following terms.

Term	Description
Address	A setting value assigned to a slave module to identify each node on the AnyWireASLINK network
Address writer	A hand-held device to read/write device parameters (including addresses) from/to a slave module
AnyWireASLINK	A reduced wiring network where sensors at the end of a control system are connected to a programmable controller. This network enables a master module to detect sensor disconnection and enables a user to set the I/O operations of an AnyWireASLINK system on the RJ51AW12AL from the upper system without using the I/O areas of the CPU module.
Buffer memory	Memory in an intelligent function module for storing data such as setting values and monitored values.
Device	A device (X, Y, M, D, or others) in a CPU module
Engineering tool	Another term for the software package for the MELSEC programmable controllers
ID	A parameter to identify whether the module is an input module or output module based on its address
Intelligent device station	A station that exchanges I/O signals (bit data) and I/O data (word data) with another station by cyclic transmission. This station responds to a transient transmission request from another station and also issues a transient transmission request to another station.
Intelligent function module	A module that has functions other than input and output, such as an A/D converter module and D/A converter module
Label	A label that represents a device in a given character string
Link device	A device (RX, RY, RWr, or RWw) in a module on CC-Link IE Field Network
Master station	A station that controls the entire network. This station can perform cyclic transmission and transient transmission with all stations. Only one master station can be used in a network.
Module label	A label that represents one of memory areas (I/O signals and buffer memory areas) specific to each module in a given character string. For the module used, GX Works3 automatically generates this label, which can be used as a global label.
Power cable (24V, 0V)	A cable that connects 24VDC external power supply to the RJ51AW12AL. This cable is also used when the isolation (4-line) type slave module and RJ51AW12AL are connected.
Terminating unit	A waveform shaper
Transmission cable (DP, DN)	A signal cable that connects between a slave module and the RJ51AW12AL
Transmission cycle time	A data sampling interval

GENERIC TERMS AND ABBREVIATION

Unless otherwise specified, this manual uses the following generic terms and abbreviations.

Term	Description
AnyWireASLINK bridge module	A generic term for the NZ2AW1C2AL and NZ2AW1GFAL
AnyWireASLINK master module	A generic term for the RJ51AW12AL, QJ51AW12AL, and LJ51AW12AL
ASLINKAMP	A generic term for sensor amplifiers that have an AnyWireASLINK interface
ASLINKER	A generic term for I/O devices that have an AnyWireASLINK interface
ASLINKMONITOR	A generic term for small display units that have an AnyWireASLINK interface
ASLINKSENSOR	A generic term for sensors that have an AnyWireASLINK interface
Bit slave module	A generic term for slave modules that communicate bit data only There are following types of bit slave module: <ul style="list-style-type: none"> • Bit input slave module • Bit output slave module • Bit I/O combined slave module Some slave modules can be operated as a word slave module depending on the setting.
CC-Link IE Field Network master/local module	A generic term for the RJ71GF11-T2, QJ71GF11-T2, QS0J71GF11-T2, LJ71GF11-T2 CC-Link IE Field Network master/local module and the following modules when the CC-Link IE Field Network function is used: <ul style="list-style-type: none"> • RJ71EN71 • RnENCPU
CPU module	A generic term for the MELSEC iQ-R series CPU modules
Data link	A generic term for cyclic transmission and transient transmission
Remote head module	An abbreviation for the RJ72GF15-T2 CC-Link IE Field Network remote head module
Slave module	A generic term for modules that communicate data with the RJ51AW12AL There are following types of slave module: <ul style="list-style-type: none"> • Bit slave module • Word slave module
Word slave module	A generic term for slave modules that communicate word data only There are following types of word slave module: <ul style="list-style-type: none"> • Word input slave module • Word output slave module • Word I/O combined slave module Some slave modules can be operated as a bit slave module depending on the setting.

1 FUNCTIONS

1.1 AnyWireASLINK Transmission

The AnyWireASLINK is a high-speed and highly reliable system which releases the work site from complicated and incorrect wiring.

In AnyWireASLINK, the RJ51AW12AL communicates with slave modules using IDs (addresses) of the slave modules.

The IDs (addresses) of the slave modules are stored in the buffer memory of the RJ51AW12AL.

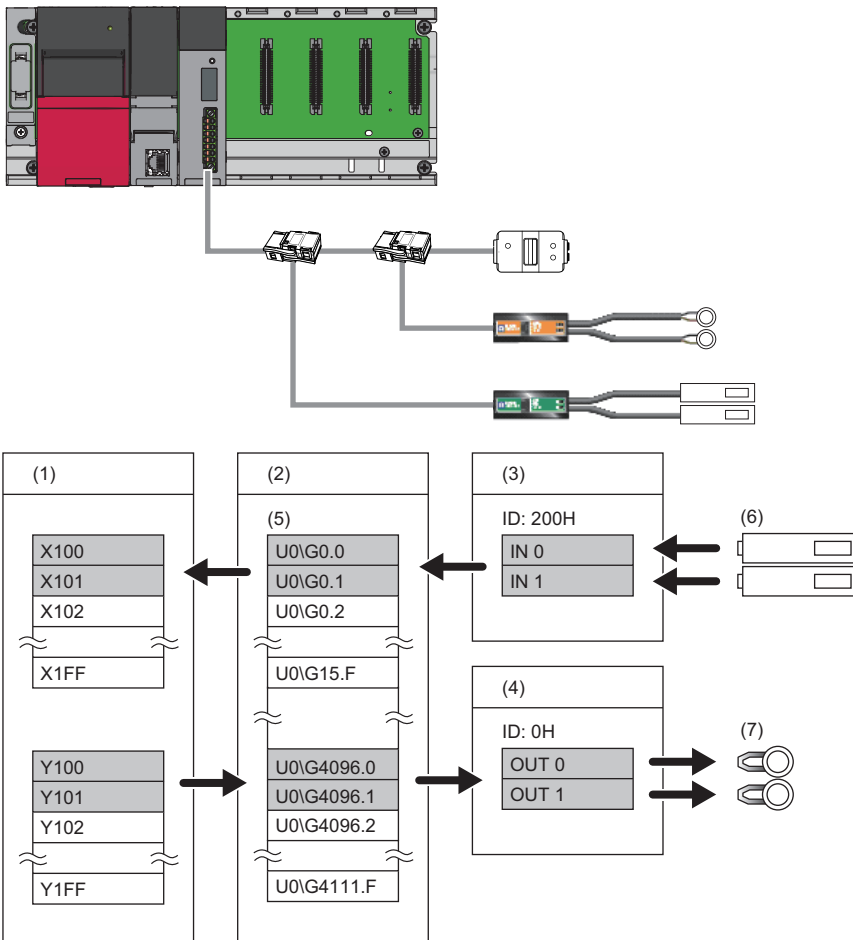

- (1) CPU module
- (2) RJ51AW12AL
- (3) Input slave module (ASLINKER): Address 0
- (4) Output slave module (ASLINKER): Address 0
- (5) Buffer memory
- (6) Sensor switch
- (7) LED

Bit transmission

In bit transmission, I/O data of up to 512 bits (input 256 bits, output 256 bits) is exchanged between the RJ51AW12AL and a slave module.

Transmission setting

Set the number of bit data points to be transmitted in "Basic setting" of the engineering tool.

 [Navigation window] ⇨ [Parameter] ⇨ [Module Information] ⇨ [RJ51AW12AL] ⇨ [Basic setting]

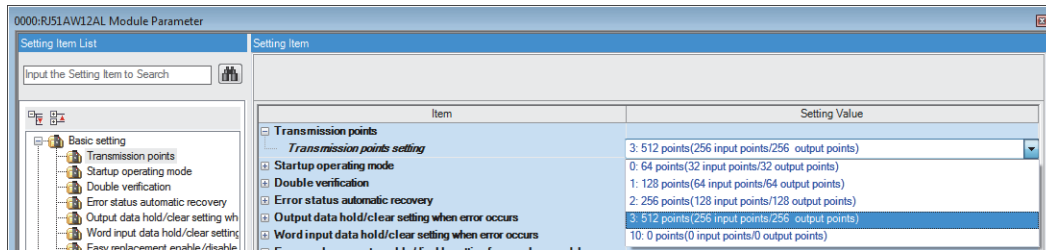

For details on the setting window, refer to the following.

 Page 49 Bit data setting

Word transmission

In word transmission, I/O data of up to 1024 words (input 512 words, output 512 words) is exchanged between the RJ51AW12AL and a slave module.

Point

- To execute word transmission, configure a system only with slave modules that support word data. Communications cannot be established between the slave module that does not support word data and the RJ51AW12AL that is performing word transmission.
- To see whether the slave modules support word transmission, refer to their manual (manufactured by Anywire Corporation).

Transmission setting

Set the number of word data points to be transmitted in "Basic setting" of the engineering tool.

[Navigation window] ⇒ [Parameter] ⇒ [Module Information] ⇒ [RJ51AW12AL] ⇒ [Basic setting]

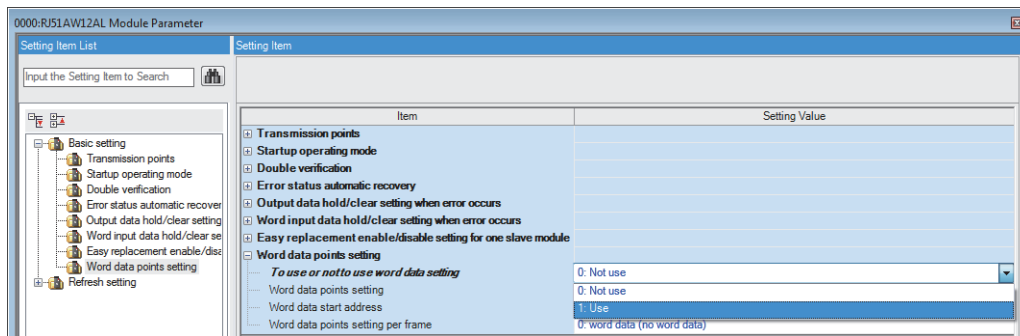

For details on the setting window, refer to the following.

☞ Page 51 Word data point setting



When using this function, check the production information of the RJ51AW12AL. (☞ Page 133 Added or Changed Functions)

1.2 Double Verification

A double verification is an error control system. In this system, cycle data in AnyWireASLINK transmission is recognized as valid data if the data matches with the data of the last transmission or is ignored as invalid data if the data does not match with the last data. The double verification ensures reliability of communication.

There are two types of double verification: double verification in 1-bit unit and double verification in 16-bit unit.

Overview

■ Double verification in 1-bit unit

If one bit of data is the same between two successive transmission cycles, the data is valid and I/O data is communicated.

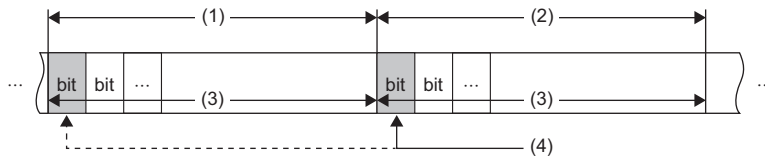

- (1) Transmission cycle (last)
- (2) Transmission cycle (current)
- (3) I/O data
- (4) This data is compared with the verification data (one bit) of the last transmission cycle.

■ Double verification in 16-bit unit

If one word (16 bits) of data is the same between two successive transmission cycles, the data is valid and I/O data is communicated.

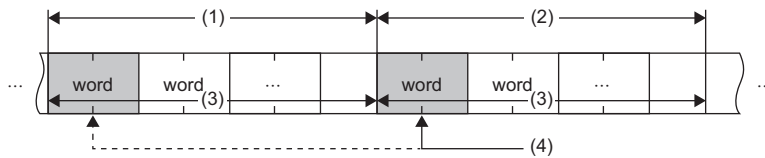

- (1) Transmission cycle (last)
- (2) Transmission cycle (current)
- (3) I/O data
- (4) The data is compared with the verification data (one word) of the last transmission cycle.

Point

The double verification in 1-bit unit is suitable for slave modules that handle information in units of bits such as ASLINKER.

The double verification in 16-bit unit is suitable for slave modules that handle information in units of 16 bits such as ASLINKAMP (analog input module).

Setting method

Set the double verification of bit data in "Double verification" of "Basic setting". (☞ Page 50 Bit data double verification setting)

Point

The double verification of word data does not need any setting.

1.3 Remote Address Change Function

With this function, an ID (address) of a slave module can be changed using the buffer memory area without an address writer.

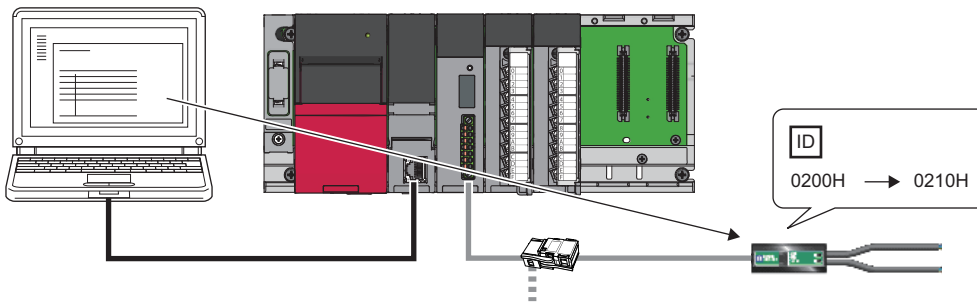

Applicable slave module

For the slave modules that support the remote address change function, consult Anywire Corporation.

Operating procedure

1. Execute automatic address detection to check that no error has occurred in the AnyWireASLINK system. (☞ Page 58 Automatic Address Detection Function)

2. Specify an access method to a slave module.

Store 0002H (remote address change) in 'Parameter access setting' (Un\G10320).

3. Specify an ID of the slave module to be accessed.

Store the ID to be changed (old ID) in 'Parameter access target module ID specification' (Un\G10321).

ID	Description
0000H to 00FEH	ID of a bit output slave module
0200H to 02FEH	ID of a bit input slave module or bit I/O combined slave module
0400H to 05FEH	ID of a word output slave module
0600H to 07FEH	ID of a word input slave module or word I/O combined slave module

4. Specify a new ID of the slave module.

Store the new ID in 'Change ID specification' (Un\G10323).

ID	Description
0000H to 00FEH	ID of a bit output slave module
0200H to 02FEH	ID of a bit input slave module or bit I/O combined slave module
0400H to 05FEH	ID of a word output slave module
0600H to 07FEH	ID of a word input slave module or word I/O combined slave module

If the specified ID has already been registered or is out of the allowable specification range, an error occurs.

5. Turn on and off 'Parameter access request command for the slave module' (Y10).

At this time, 'Parameter access completion flag' (X11) turns off, and 'Parameter accessing flag (with handshake)' (XB) turns on. When the parameter access is completed, 'Parameter access completion flag' (X11) automatically turns on.

6. After changing the IDs of all the target slave modules, execute automatic address detection. (☞ Page 58 Automatic Address Detection Function)

Precautions

- Before executing this function, make sure to execute automatic address detection to check that no error has occurred in the AnyWireASLINK system. (☞ Page 58 Automatic Address Detection Function)
- This function cannot be executed for slave modules separated from the RJ51AW12AL because of disconnection or slave modules having the same ID. Use an address writer to change the IDs of such slave modules.
- This function can be executed if only one slave module having no ID exists within one AnyWireASLINK line. If IDs of multiple slave modules are not set, it is recognized as an ID duplication. Thus, the IDs cannot be changed.

1.4 Same ID Used Detection Function

This function checks whether the same ID is used for multiple slave modules through automatic address detection or same address used check. The LEDs of the relevant slave modules are forcibly turned on.

Point

- ID duplications are detected through automatic address detection or same address used check. If the CPU module is reset or the power is turned off after ID duplication detection, the same ID used status cannot be checked until automatic address detection or same address used check is executed again.
- Even if an ID is assigned to multiple modules, a single ID is stored in 'Number of the alarm IDs' (Un\G9984) and 'Alarm ID information storage area' (Un\G9985 to Un\G10112). For example, even when multiple modules have an ID 000AH, "1" is stored in 'Number of the alarm IDs' (Un\G9984) and "000AH" is stored in 'Alarm ID information storage area' (Un\G9985 to Un\G10112).

How to execute automatic address detection

For details on automatic address detection, refer to the following.

 Page 58 Automatic Address Detection Function

How to execute same address used check

Turn off and on 'Overlap address inspection command' (Y2). If 'Overlap address inspection flag' (X15) turns on and off, it indicates that the same address used check is completed.

The same address used check cannot be executed under any of the following conditions.

- When an error occurs in the AnyWireASLINK system (Example: Short circuit, 24VDC external power supply voltage drop)
- Within approximately five seconds after the AnyWireASLINK system is powered on or system is reset
- While 'Adjustment mode executing flag' (XF) is on
- While 'Parameter access completion flag' (X11) is off
- When the automatic address detection is in progress (While 'Automatic address detection flag' (X14) is on)
- When the same address used check is in progress (While 'Overlap address inspection flag' (X15) is on)
- When the parameter access is in progress (While 'Parameter access request command for the slave module' (Y10), 'Parameter batch read command for the slave module' (Y11), or 'Parameter batch write command for the slave module' (Y12) is on)
- When any of the following errors has occurred

Error code	Error description
0CC8H	Transmission cable voltage drop error
0CC9H	DP/DN short error
0CCBH	24V/DP short error
3064H	RJ51AW12AL hardware failure
3065H	
3066H	
3068H	CPU module stop error (IORSTL signal detection)
3069H	System error (NMI signal detection)
306BH	CPU module error (ITERR signal detection)
306CH	ASIC access error (library I/F function access error)

How to check the same ID used status

When the AnyWireASLINK system is in the following status, the same ID is used for multiple modules.

Even in the same ID used status, the AnyWireASLINK transmission does not stop.

- 'Slave module alarm signal' (X10) turns on.
- Same ID used error (error code: 0D90H) is stored in 'Latest error code storage area' (Un\G10256) and the same ID is stored in 'Latest error ID storage area' (Un\G10257).^{*1}
- An error (error code: 0D90H) is displayed on an engineering tool. (☞ Page 75 Checking with the "Module Diagnostics" window)^{*1}
- The relevant ID is stored in 'Alarm ID information storage area' (Un\G9985 to Un\G10112).

*1 If multiple errors occur simultaneously, the latest error is displayed.

How to recover from same ID used status

Check 'Number of the alarm IDs' (Un\G9984) and 'Alarm ID information storage area' (Un\G9985 to Un\G10112). Then set a unique ID (address) in all the slave modules. (☞ Page 102 Number of the alarm IDs, Page 103 Alarm ID information storage area)

Set IDs (addresses) of slave modules and execute automatic address detection of the RJ51AW12AL. Then, the IDs of the slave modules are stored in the RJ51AW12AL and the error is cleared. (☞ Page 58 Automatic Address Detection Function)

Precautions

While an ID (address) is used for multiple slave modules, executing either of the following can eliminate the same ID used error. However, the address is still used for the multiple slave modules.

- Powering off and on the AnyWireASLINK system
- Turning off and on 'Error flag clear command' (Y0)

1.5 Module with No ID Setting Detection Function

This function detects slave modules with no ID assigned (default ID) through automatic address detection or same address used check.

Module ^{*1*2}	Default ID
Input slave module, I/O combined slave module	02FFH
Output slave module	00FFH

*1 Bit slave modules and word slave modules have the same default ID.

*2 The default address of bit slave modules is 255 or 511.

The default address of word slave modules is 511.

Point

- Modules with no ID set are detected through automatic address detection or same address used check. If the CPU module is reset or the power is turned off after a module with no ID set is detected, the no ID number setting status cannot be checked until automatic address detection or same address used check is executed again.
- Even if no ID is assigned to modules, a single ID is stored in 'Number of the alarm IDs' (Un\G9984) and 'Alarm ID information storage area' (Un\G9985 to Un\G10112). For example, even when multiple modules have an ID 00FFH, "1" is stored in 'Number of the alarm IDs' (Un\G9984) and "00FFH" is stored in 'Alarm ID information storage area' (Un\G9985 to Un\G10112).

How to execute automatic address detection

For details on automatic address detection, refer to the following.

 Page 58 Automatic Address Detection Function

How to execute same address used check

Turn off and on 'Overlap address inspection command' (Y2). If 'Overlap address inspection flag' (X15) turns on and off, it indicates that the same address used check is completed.

The same address used check cannot be executed under any of the following conditions.

- When an error occurs in the AnyWireASLINK system (Example: Short circuit, 24VDC external power supply voltage drop)
- Within approximately five seconds after the AnyWireASLINK system is powered on or system is reset
- While 'Adjustment mode executing flag' (XF) is on
- While automatic address detection is in progress (While 'Automatic address detection flag' (X14) is on)
- When the same address used check is in progress (While 'Overlap address inspection flag' (X15) is on)
- When the parameter access is in progress (While 'Parameter access request command for the slave module' (Y10), 'Parameter batch read command for the slave module' (Y11), or 'Parameter batch write command for the slave module' (Y12) is on)
- When any of the following errors has occurred

Error code	Error description
0CC8H	Transmission cable voltage drop error
0CC9H	DP/DN short error
0CCBH	24V/DP short error
3064H	RJ51AW12AL hardware failure
3065H	
3066H	
3068H	CPU module stop error (IORSTL signal detection)
3069H	System error (NMI signal detection)
306BH	CPU module error (ITERR signal detection)
306CH	ASIC access error (library I/F function access error)

How to check the no ID number setting status

When the AnyWireASLINK system is in the following status, no ID number setting status is detected.

Even in the no ID number setting status, the AnyWireASLINK transmission does not stop.

- 'Slave module alarm signal' (X10) turns on.
- No ID setting error (error code: 0D91H) is stored in 'Latest error code storage area' (Un\G10256) and unset IDs are stored in 'Latest error ID storage area' (Un\G10257).^{*1}
- An error (error code: 0D91H) is displayed on an engineering tool. (☞ Page 75 Checking with the "Module Diagnostics" window)^{*1}
- Unset IDs are stored in 'Alarm ID information storage area' (Un\G9985 to Un\G10112).

*1 If multiple errors occur simultaneously, the latest error is displayed.

How to recover from the no ID number setting status

Check 'Number of the alarm IDs' (Un\G9984) and 'Alarm ID information storage area' (Un\G9985 to Un\G10112). Then set addresses to slave modules. (☞ Page 102 Number of the alarm IDs, Page 103 Alarm ID information storage area)

Check that the following address is not set as the address of the slave module.

Model	Address
Bit slave module	255, 511
Word slave module	511

Set IDs (addresses) of slave modules and execute automatic address detection of the RJ51AW12AL. Then, the IDs of the slave modules are stored in the RJ51AW12AL and the error is cleared. (☞ Page 58 Automatic Address Detection Function)

Point

For operations of slave modules with no ID assigned (default ID), refer to the following.

 Manual of the slave module used (manufactured by Anywire Corporation)

Precautions

While an ID (address) of a slave module is not set, executing either of the following can eliminate the no ID setting error.

However the address of the slave module is still not set.

- Powering off and on the AnyWireASLINK system
- Turning off and on 'Error flag clear command' (Y0)

1.6 Transmission Cable Short Detection Function

This function protects the system by detecting the current out of the specifications of the AnyWireASLINK system across DP-DN or 24V-DP and stopping the transmission.

How to check the transmission cable short status

When the AnyWireASLINK system is in the following status, a transmission cable short has occurred.

- The ALM LED flashes at 2-second intervals.*¹
- When any of the transmission cables (DP, DN) is short-circuited, 'DP/DN short error' (X1) turns on.
- When any of the transmission cables (24V, DP) is short-circuited, '24V/DP short error' (X2) turns on.
- DP/DN short error (error code: 0CC9H) or 24V/DP short error (error code: 0CCBH) is stored in 'Latest error code storage area' (Un\G10256) and 0FFFH is stored in 'Latest error ID storage area' (Un\G10257).*¹
- An error (error code: 0CC9H or 0CCBH) is displayed on an engineering tool. (🔍 Page 75 Checking with the "Module Diagnostics" window)*¹
- The AnyWireASLINK transmission stops.

*¹ If multiple errors occur simultaneously, the latest error is displayed.

How to recover from the transmission cable short status

How to recover from the transmission cable short status is as follows.

1. Eliminate the short circuit in the AnyWireASLINK system.

When the short status is exited, the AnyWireASLINK transmission resumes automatically.

If the status does not change, the short circuit has not been eliminated. Check it again.

2. Power off and on the AnyWireASLINK system or turn on and off 'Error flag clear command' (Y0).

The following status is resulted:

- 'DP/DN short error' (X1) and '24V/DP short error' (X2) turn off.
- The ALM LED turns off.
- The data in 'Latest error code storage area' (Un\G10256) and 'Latest error ID storage area' (Un\G10257) are cleared.

1.7 Disconnected Transmission Cable Location Detection Function

This function notifies the ID of a slave module that has been separated from the RJ51AW12AL because of disconnection in the transmission cables (DP, DN) between the RJ51AW12AL and the slave module, to locate the disconnection in the transmission cables (DP, DN) from the upper system.

Point

- To enable the disconnected transmission cable location detection function, execute automatic address detection when configuring, modifying, or expanding the system. ( Page 58 Automatic Address Detection Function)
- After a system is configured, the disconnection detection may work when a slave module is disconnected from the system. Execute automatic address detection after modifying the system.
- Even if disconnection in the transmission cable (DP, DN) is detected, the AnyWireASLINK transmission does not stop.

How to check the transmission cable disconnection status

When the AnyWireASLINK system is in the following status, the transmission cable (DP, DN) have been disconnected or a slave module error has occurred.

- The ALM LED turns on. ^{*1}
- 'DP/DN disconnection error' (X4) turns on.
- The number of error IDs is stored in 'Number of the error IDs' (Un\G8192).
- The disconnected ID (address) is stored in 'Error ID information storage area' (Un\G8193 to Un\G8320).
- The bits corresponding to disconnected IDs (addresses) of the following buffer memory areas turn on.

Address	Name
Un\G8704 to Un\G8719	Error ID information bit area (bit output)
Un\G8736 to Un\G8751	Error ID information bit area (bit input)
Un\G8768 to Un\G8799	Error ID information bit area (word output)
Un\G8800 to Un\G8831	Error ID information bit area (word input)

- DP/DN disconnection error (error code: 0CCAH) is stored in 'Latest error code storage area' (Un\G10256) and the disconnected ID is stored in 'Latest error ID storage area' (Un\G10257). ^{*1}
- An error (error code: 0CCAH) is displayed on an engineering tool. ( Page 75 Checking with the "Module Diagnostics" window) ^{*1}

^{*1} If multiple errors occur simultaneously, the latest error is displayed.

How to recover from the transmission cable disconnection status

How to recover from the transmission cable disconnection status is as follows.

1. Eliminate the disconnection in the AnyWireASLINK system.

When the disconnection status is exited, the AnyWireASLINK transmission resumes automatically.

When the slave module has been disconnected from the system, execute automatic address detection. (☞ Page 58 Automatic Address Detection Function)

2. Power off and on the AnyWireASLINK system or turn on and off 'Error flag clear command' (Y0).

The following status is resulted:

- 'DP/DN disconnection error' (X4) turns off.
- The ALM LED turns off.
- The data in 'Latest error code storage area' (Un\G10256) and 'Latest error ID storage area' (Un\G10257) are cleared.

Point

- When the automatic address detection is executed in the step 1, the operation in the step 2 is not necessary.
- When the error status automatic recovery mode is enabled by "Error status automatic recovery" of "Basic setting", the error is automatically cleared after the disconnection status is exited.

1.8 Transmission Cable Voltage Drop Detection Function

This function detects a voltage drop in the 24VDC external power supply, enabling the RJ51AW12AL to detect a failure in the 24VDC external power supply or a wiring error from the upper system.

Point

For the specifications of the 24VDC external power supply to the RJ51AW12AL, refer to the following.
 MELSEC iQ-R AnyWireASLINK Master Module User's Manual (Startup)

How to check the transmission cable voltage drop status

When the AnyWireASLINK system is in the following status, a voltage drop in the 24VDC external power supply has been detected.

- The ALM LED flashes at 0.4-second intervals.*1
- 'Transmission cable voltage drop error' (X3) turns on.
- Transmission cable voltage drop error (error code: 0CC8H) is stored in 'Latest error code storage area' (Un\G10256) and 0FFFH is stored in 'Latest error ID storage area' (Un\G10257).*1
- An error (error code: 0CC8H) is displayed on an engineering tool. ( Page 75 Checking with the "Module Diagnostics" window)*1
- The AnyWireASLINK transmission stops.

*1 If multiple errors occur simultaneously, the latest error is displayed.

How to recover from the transmission cable voltage drop status

How to recover from the transmission cable voltage drop status is as follows.

- 1.** Check the voltage of the 24VDC external power supply and replace the power supply or check the wiring, as necessary. When the transmission cable voltage drop is corrected, the AnyWireASLINK transmission resumes automatically.
- 2.** Power off and on the AnyWireASLINK system or turn on and off 'Error flag clear command' (Y0).

The following status is resulted:

- 'Transmission cable voltage drop error' (X3) turns off.
- The ALM LED turns off.
- The data in 'Latest error code storage area' (Un\G10256) and 'Latest error ID storage area' (Un\G10257) are cleared.

1.9 Parameter Access Error Detection Function

This function allows parameter access errors to be detected.

- Slave module hardware error (error code: 0D2CH, 0D2DH)
- Parameter access target module ID error (error code: 0D2EH)
- Parameter value error (error code: 0D2FH)
- Parameter access error (error code: 0D30H)
- Slave module status error (error code: 0D31H)
- Type mismatch error (error code: 0D80H)
- Replacement error due to use of slave module of earlier device version (error code: 0D81H)
- Same ID used error (error code: 0D90H)
- No ID setting error (error code: 0D91H)
- New ID error (error code: 0D92H)

How to check the parameter access error status

The following table lists parameter access error statuses.

Error description	Status when an error occurred		Engineering tool
	I/O signal	Buffer memory area	
Slave module hardware error	'Slave module alarm signal' (X10) turns on.	■'Latest error code storage area' (Un\G10256) The error code is stored.* ¹ ■'Latest error ID storage area' (Un\G10257) The IDs corresponding to the error codes are stored. ■'Number of the alarm IDs' (Un\G9984) The number of IDs relevant to alarm occurrence is stored. ■'Alarm ID information storage area' (Un\G9985 to Un\G10112) The IDs relevant to alarm occurrence are stored.	The error code is displayed in the "Module Diagnostics" window. (Page 75 Checking with the "Module Diagnostics" window)* ¹
Parameter value error			
Slave module status error			
Same ID used error			
No ID setting error			
Parameter access error	'Parameter access error' (X12) turns on.	■'Latest error code storage area' (Un\G10256) The error code is stored.* ¹ ■'Latest error ID storage area' (Un\G10257) The IDs corresponding to the error codes are stored. ■'Number of the error IDs' (Un\G8192) The number of IDs relevant to error occurrence is stored. ■'Error ID information storage area' (Un\G8193 to Un\G8320) IDs relevant to error occurrence are stored. ■'Error ID information bit area (bit output)' (Un\G8704 to Un\G8719) IDs relevant to error occurrence are stored in units of bits. ■'Error ID information bit area (bit input)' (Un\G8736 to Un\G8751) IDs relevant to error occurrence are stored in units of bits. ■'Error ID information bit area (word output)' (Un\G8768 to Un\G8799) IDs relevant to error occurrence are stored in units of bits. ■'Error ID information bit area (word input)' (Un\G8800 to Un\G8831) IDs relevant to error occurrence are stored in units of bits.	
Parameter access target module ID error	'Slave module alarm signal' (X10) turns on.	■'Latest error code storage area' (Un\G10256) The error code is stored.* ¹ ■'Latest error ID storage area' (Un\G10257) The IDs corresponding to the error codes are stored.	
Type mismatch error			
Replacement error due to use of slave module of earlier device version			
New ID error			

*1 If multiple errors occur simultaneously, the latest error is displayed.

How to recover from the parameter access error status

For recovery from the parameter access error status, refer to the following.

☞ Page 80 List of Error Codes

To recover from the parameter access error status, eliminate the error cause, and power off and on the AnyWireASLINK system or turn off and on 'Error flag clear command' (Y0).

Status after recovery

After recovery from parameter access error status, the following status is resulted:

Error description	Signal status	
Slave module hardware error	<ul style="list-style-type: none"> 'Slave module alarm signal' (X10) turns off. The data in 'Latest error code storage area' (Un\G10256) is cleared. The data in 'Latest error ID storage area' (Un\G10257) is cleared. The data in 'Number of the alarm IDs' (Un\G9984) is cleared. The data in 'Alarm ID information storage area' (Un\G9985 to Un\G10112) is cleared. 	
Parameter value error*1		
Slave module status error		
Same ID used error*1		
No ID setting error*1		
Parameter access error	<ul style="list-style-type: none"> 'Parameter access error' (X12) turns off. The data in 'Latest error code storage area' (Un\G10256) is cleared. The data in 'Latest error ID storage area' (Un\G10257) is cleared. The data in 'Number of the error IDs' (Un\G8192) is cleared. The data in 'Error ID information storage area' (Un\G8193 to Un\G8320) is cleared. The data in 'Error ID information bit area (bit output)' (Un\G8704 to Un\G8719) is cleared. The data in 'Error ID information bit area (bit input)' (Un\G8736 to Un\G8751) is cleared. The data in 'Error ID information bit area (word output)' (Un\G8768 to Un\G8799) is cleared. The data in 'Error ID information bit area (word input)' (Un\G8800 to Un\G8831) is cleared. 	
Parameter access target module ID error		
Type mismatch error		
Replacement error due to use of slave module of earlier device version		
New ID error		
		<ul style="list-style-type: none"> 'Slave module alarm signal' (X10) turns off. The data in 'Latest error code storage area' (Un\G10256) is cleared. The data in 'Latest error ID storage area' (Un\G10257) is cleared.

*1 When factors causing errors are eliminated, the data in 'Number of the alarm IDs' (Un\G9984) and 'Alarm ID information storage area' (Un\G9985 to Un\G10112) are cleared.

1.10 Error Status Automatic Recovery Function

This function allows for automatic error reset for DP/DN disconnection errors and parameter access errors after the error status is cleared.

If this function is not used, it is necessary to eliminate the error cause, and power off and on the AnyWireASLINK system or turn on and off 'Error flag clear command' (Y0).

Error that can be automatically recovered

The following shows the errors that can be automatically recovered.

Error code	Error description	Status when an error occurred	Status when an error is cleared
0CCA H	DP/DN disconnection error	<ul style="list-style-type: none"> 'DP/DN disconnection error' (X4) turns on. Error ID information is registered in the buffer memory address. (☞ Page 26 How to check the transmission cable disconnection status) 	<ul style="list-style-type: none"> 'DP/DN disconnection error' (X4) turns off.*1 The error ID information registered in the buffer memory address is cleared. (corresponding ID only)*2
0D30 H	Parameter access error	<ul style="list-style-type: none"> 'Parameter access error' (X12) turns on. Error ID information is registered in the buffer memory address. (☞ Page 29 How to check the parameter access error status) 	<ul style="list-style-type: none"> 'Parameter access error' (X12) turns off.*1 The error ID information registered in the buffer memory address is cleared. (corresponding ID only)*2

*1 The error causes must be eliminated from all the slave modules in which errors have occurred.

*2 If the errors 0CCA H and 0D30 H have occurred in one slave module, the causes of both the errors must be eliminated.

Setting method

Set the error status automatic recovery function in "Error status automatic recovery" of "Basic setting". (☞ Page 50 Error status automatic recovery setting)

1.11 Slave Module Information Acquisition at Start-up Function

This function allows for automatic acquisition of information of slave modules when the CPU module is reset or the power is turned off and on.

The slave module information acquisition at start-up function eliminates the needs for reading parameters from slave modules.

For the parameters of the slave module stored, refer to the following.

 Page 33 Slave Module Parameter Read/Write

Setting method

Set the slave module information acquisition at start-up function in "Startup operating mode" of "Basic setting". ( Page 49 Startup operating mode setting)

Operation at start-up





When communication of the RJ51AW12AL is normally established after the CPU module is reset or the power is turned off and on, the parameters of all the registered slave modules are read at a time. The read parameters are then stored in the buffer memory.

1.12 Slave Module Parameter Read/Write

In the AnyWireASLINK transmission, in addition to I/O data, parameter information of a slave module and the AnyWireASLINK system is sent and received between the RJ51AW12AL and the slave module.

Use this function to check or change parameter information of a slave module.

For details on the parameter information to be communicated, refer to the following.

-  Page 104 Parameter access setting
-  Page 104 Parameter access target module ID specification
-  Page 105 Parameter storage location memory number
-  Page 107 Parameter storage area

Parameter reading and writing methods

There are four methods as follows to read or write the parameter information from or to a slave module.

Type	Description
Automatic update	The status details and the sensing level of all slave modules are read at regular intervals. (Setting values are excluded.)
Parameter access	All the parameter values of the slave modules are read or written individually in accordance with the setting of reading or writing and the target slave module.
Parameter batch read	All the parameter values of all slave modules are read out into the buffer memory of the RJ51AW12AL.
Parameter batch write	Values set in the buffer memory of the RJ51AW12AL are written to all the parameter of all slave modules.

The following shows the readable/writable parameters.

○: Possible, ×: Impossible

Parameter name	Read/write	Parameter read and write methods					
		Automatic update	Parameter access		Parameter batch read	Parameter batch write	
			Read	Write			
Device parameter* ¹	Read/write	×	○	○	○	○	
AnyWireASLINK parameter	Module ID	Read	×	○	×	○	×
	Status details	Read	○	○	×	○	×
	Sensing level	Read	○	○	×	○	×

*1 The device parameter name differs depending on the slave module to be used.



Parameter access, parameter batch read, or parameter batch write does not affect the AnyWireASLINK transmission cycle time.

Automatic update

No special operation is required because data are automatically updated. To check the parameter information, refer to the corresponding buffer memory address.

Parameter access

The operating procedure for parameter access is as follows.

■To read parameters

1. Set the access method.

Store 0000H (read) in 'Parameter access setting' (Un\G10320).

2. Set the access target ID.

Store the access target ID in 'Parameter access target module ID specification' (Un\G10321).

ID	Description
0000H to 00FEH	ID of a bit output slave module
0200H to 02FEH	ID of a bit input slave module or bit I/O combined slave module
0400H to 05FEH	ID of a word output slave module
0600H to 07FEH	ID of a word input slave module or word I/O combined slave module

3. Turn off and on 'Parameter access request command for the slave module' (Y10).

At this time, 'Parameter access completion flag' (X11) turns off. In addition, 'Parameter accessing flag (with handshake)' (XB) turns on.

4. When the parameter access is completed, 'Parameter access completion flag' (X11) automatically turns on.

5. Turn on and off 'Parameter access request command for the slave module' (Y10).

6. When 'Parameter access completion flag' (X11) turns on and the following signals are turned off, 'Parameter accessing flag (with handshake)' (XB) turns off.

- 'Parameter access request command for the slave module' (Y10)
- 'Parameter batch read command for the slave module' (Y11)
- 'Parameter batch write command for the slave module' (Y12)

7. The read parameters are stored in the following location of each ID.

Device parameter in 'Parameter storage area' (Un\G12288 to Un\G12335) *1

*1 Buffer memory addresses when one slave module is connected. For details, refer to the following.

 Page 107 Parameter storage area

■ To write parameters

1. Read the parameters referring to the procedure in "To read parameters" or "Parameter batch read".

Before executing parameter write, read the parameters of all slave modules of which IDs have been registered.*1

*1 Because parameter write updates all parameters of target slave modules, all parameters to which no changes are made need to be set correctly.

Executing parameter write without executing parameter read will result in a malfunction.

2. Set the access method.

Store 0001H (write) in 'Parameter access setting' (Un\G10320).

3. Set the access target ID.

Store the access target ID in 'Parameter access target module ID specification' (Un\G10321).

ID	Description
0000H to 00FEH	ID of a bit output slave module
0200H to 02FEH	ID of a bit input slave module or bit I/O combined slave module
0400H to 05FEH	ID of a word output slave module
0600H to 07FEH	ID of a word input slave module or word I/O combined slave module

4. Store the parameters to be written in the following location.

Device parameter read/write areas in 'Parameter storage area' (Un\G12288 to Un\G12335) *1

*1 Buffer memory addresses when one slave module is connected. For details, refer to the following.

☞ Page 107 Parameter storage area

5. Turn off and on 'Parameter access request command for the slave module' (Y10).

At this time, 'Parameter access completion flag' (X11) turns off. In addition, 'Parameter accessing flag (with handshake)' (XB) turns on.

6. When the parameter access is completed, 'Parameter access completion flag' (X11) automatically turns on.

7. Turn on and off 'Parameter access request command for the slave module' (Y10).

8. When 'Parameter access completion flag' (X11) turns on and the following signals are turned off, 'Parameter accessing flag (with handshake)' (XB) turns off.

- 'Parameter access request command for the slave module' (Y10)
- 'Parameter batch read command for the slave module' (Y11)
- 'Parameter batch write command for the slave module' (Y12)

9. After executing parameter write, read the parameters of the slave module referring to the procedure in "To read parameters" or "Parameter batch read" to check that the parameters have been correctly applied to the slave modules.

Parameter batch read

The procedure for parameter batch read is as follows.

1. Turn off and on 'Parameter batch read command for the slave module' (Y11).

At this time, 'Parameter access completion flag' (X11) turns off. In addition, 'Parameter accessing flag (with handshake)' (XB) turns on.

2. When the parameter access is completed, 'Parameter access completion flag' (X11) automatically turns on.
3. Turn on and off 'Parameter batch read command for the slave module' (Y11).
4. When 'Parameter access completion flag' (X11) turns on and the following signals are turned off, 'Parameter accessing flag (with handshake)' (XB) turns off.

- 'Parameter access request command for the slave module' (Y10)
- 'Parameter batch read command for the slave module' (Y11)
- 'Parameter batch write command for the slave module' (Y12)

5. The read parameters are stored in the following location of each ID.

Device parameter in 'Parameter storage area' (Un\G12288 to Un\G12335) *1

*1 Buffer memory addresses when one slave module is connected. For details, refer to the following.

 Page 107 Parameter storage area

Parameter batch write

The operating procedure for parameter batch write is as follows.

1. Read the parameters referring to the procedure in "Parameter batch read".

Read the parameters of all slave modules with registered IDs before executing parameter batch read.* 1

*1 Because parameter batch write updates all parameters of target slave modules, all parameters to which no changes are made need to be set correctly.

Executing parameter batch write without executing parameter batch read will result in a malfunction.

2. Store the parameters to be written in the following location.

Device parameter read/write areas in 'Parameter storage area' (Un\G12288 to Un\G12335) *1

*1 Buffer memory addresses when one slave module is connected. For details, refer to the following.

 Page 107 Parameter storage area

3. Turn off and on 'Parameter batch write command for the slave module' (Y12).

At this time, 'Parameter access completion flag' (X11) turns off. In addition, 'Parameter accessing flag (with handshake)' (XB) turns on.

4. When the parameter access is completed, 'Parameter access completion flag' (X11) automatically turns on.
5. Turn on and off 'Parameter batch write command for the slave module' (Y12).
6. When 'Parameter access completion flag' (X11) turns on and the following signals are turned off, 'Parameter accessing flag (with handshake)' (XB) turns off.

- 'Parameter access request command for the slave module' (Y10)
- 'Parameter batch read command for the slave module' (Y11)
- 'Parameter batch write command for the slave module' (Y12)

7. After executing parameter batch write, read the parameters of the slave module referring to the procedure in "To read parameters" or "Parameter batch read" to check that the parameters have been correctly applied to the slave modules.

Point

- During the parameter access, parameter batch read, and parameter batch write, 'Parameter access completion flag' (X11) is off.
- When "Parameter access completion flag' (X11) is off, the parameter access, parameter batch read, parameter batch write, and AnyWireASLINK version compatibility inspection cannot be performed.
- Upon parameter batch read or parameter batch write, the values stored in 'Parameter access setting' (Un\G10320) and 'Parameter access target module ID specification' (Un\G10321) are ignored.

Parameter information storage location

The parameter information storage location differs depending on the slave module to be used.

Slave module	Parameter storage location memory number	Parameter information storage location
Bit output slave module	Un\G10496 to Un\G10751	48 words from the buffer memory start address
Bit input slave module or bit I/O combined slave module	Un\G11008 to Un\G11263	
Word output slave module	Un\G19456 to Un\G19967	
Word input slave module or word I/O combined slave module	Un\G19968 to Un\G20479	

Parameter access timing

The parameter access timing is as follows.

- ▶ Executed in the program
 —————▶ Executed by the RJ51AW12AL

'Parameter access request command for the slave module' (Y10),
 'Parameter batch read command for the slave module' (Y11),
 'Parameter batch write command for the slave module' (Y12)

'Parameter access completion flag' (X11)

'Parameter access error' (X12)

'Error flag clear command' (Y0)

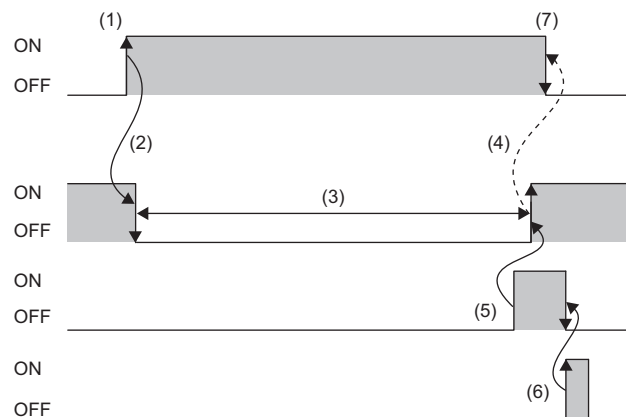

No.	Description
(1)	Turn off and on any of the signals below with a program to start parameter access.*1 • 'Parameter access request command for the slave module' (Y10) • 'Parameter batch read command for the slave module' (Y11) • 'Parameter batch write command for the slave module' (Y12)
(2)	The operation in (1) turns off 'Parameter access completion flag' (X11).
(3)	The parameter access is in progress.
(4)	When parameter access (read/write) is completed, 'Parameter access completion flag' (X11) automatically turns off and on.
(5)	If parameter access has an error, 'Parameter access error' (X12) turns off and on and 'Parameter access completion flag' (X11) automatically turns off and on.*2
(6)	Turning off and on 'Error flag clear command' (Y0) with a program turns on and off 'Parameter access error' (X12).
(7)	Turn on and off the signal that has been turned off and on in the step (1) with a program.

*1 Before the start of parameter access from the RJ51AW12AL to the slave module, apply the access method, access target ID, and parameter data to the buffer memory.

*2 Error codes are stored in 'Latest error code storage area' (Un\G10256) and the target IDs are stored in 'Latest error ID storage area' (Un\G10257). (The latest information is overwritten.)

Check of the parameter access completion

When parameter access is executed from the RJ51AW12AL to a slave module, the completion of the parameter access can be checked in 'Parameter accessing flag (with handshake)' (XB).

The following shows the completion timing of the parameter access using Parameter accessing flag (with handshake)' (XB).



When using this function, check the production information of the RJ51AW12AL. (☞ Page 133 Added or Changed Functions)

■When Y10, Y11, or Y12 is turned off after the parameter access processing is completed

—————▶ Executed by the RJ51AW12AL

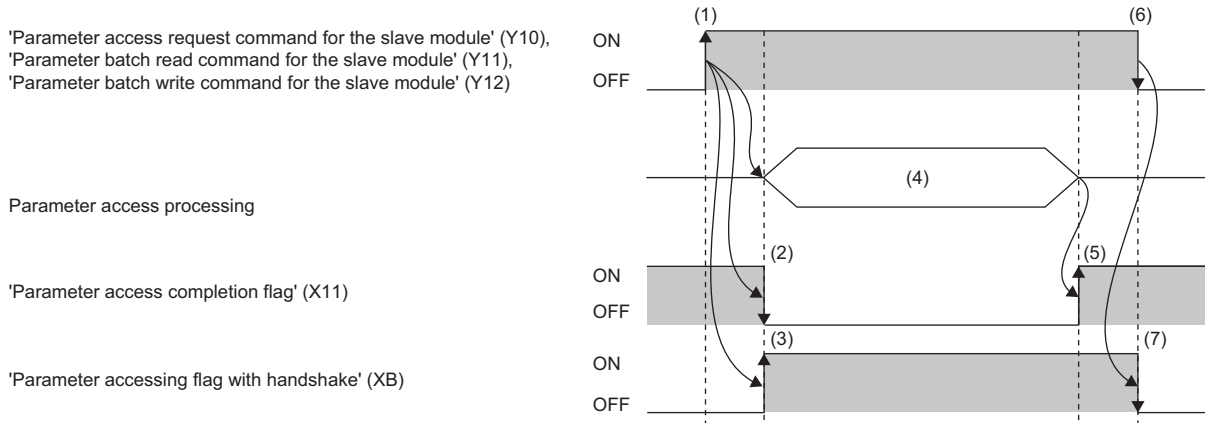

- (1) Turn off and on any of the signals at any time to start the parameter access.
- (2) The signal turns on and off the moment the parameter access processing starts.
- (3) The signal starts and on the moment the parameter access processing starts.
- (4) The parameter access is in progress.
- (5) The signal turns off and on the moment the parameter access processing is completed.
- (6) Turn on and off the signal at any time.
- (7) The signal turns on and off when the output signal is turned on and off in (6) after the parameter access processing is completed.

■When Y10, Y11, or Y12 is turned off before the parameter access processing is completed

—————▶ Executed by the RJ51AW12AL

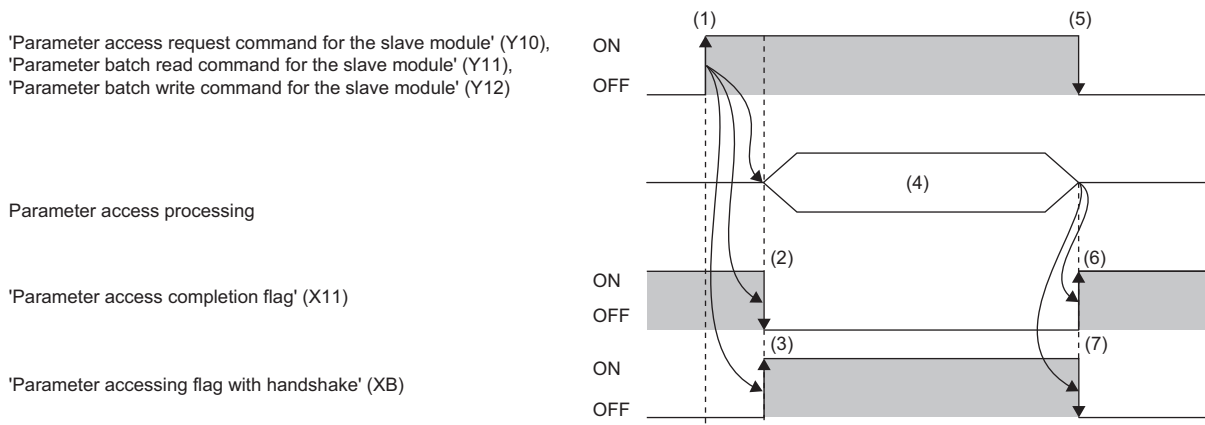

- (1) Turn off and on any of the signals at any time to start the parameter access.
- (2) The signal turns on and off the moment the parameter access processing starts.
- (3) The signal starts and on the moment the parameter access processing starts.
- (4) The parameter access is in progress.
- (5) Turn on and off the signal at any time.
- (6) The signal turns off and on the moment the parameter access processing is completed.
- (7) The signal turns on and off the moment the parameter access processing is completed.

■When Y10, Y11, or Y12 is turned off before the parameter access processing starts.

—————▶ Executed by the RJ51AW12AL

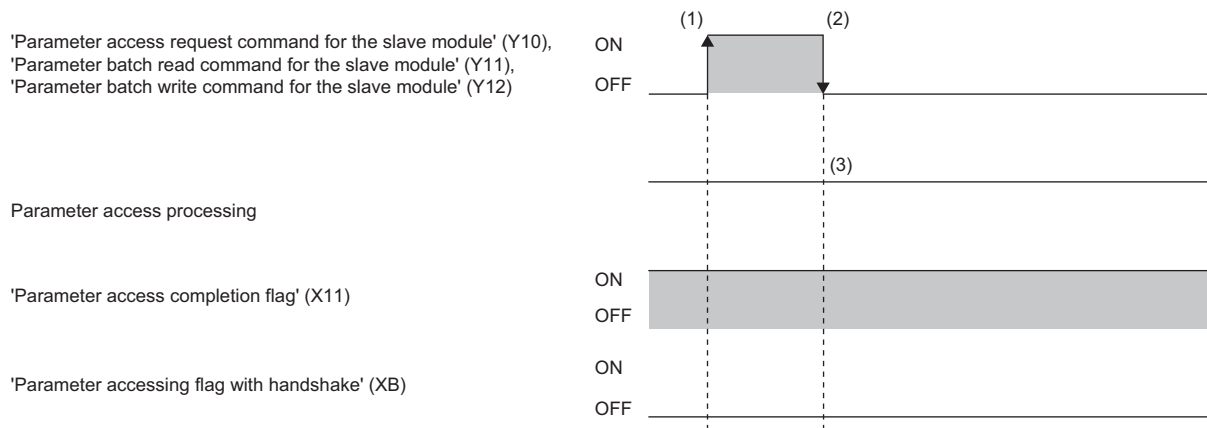

(1) Turn off and on any of the signals at any time to start the parameter access.

(2) Turn on and off the signal at any time.

(3) The parameter access will not be executed when Y10, Y11, or Y12 is turned off before the parameter access processing starts.

Point

- To start the parameter access processing using Y10, Y11, or Y12, Y10, Y11, or Y12 must be on until 'Parameter accessing flag (with handshake)' (XB) turns off and on. When Y10, Y11, or Y12 is turned on and off before 'Parameter accessing flag (with handshake)' (XB) turns off and on, the parameter access processing does not start.
- When any of Y10, Y11, or Y12 is turned on, 'Parameter accessing flag (with handshake)' (XB) does not turn on and off.

■Precautions

Under the following conditions, the parameter access processing does not start even when any of Y10, Y11, or Y12 is turned off and on. Turn on the signal after the parameter access processing becomes enabled.

- 'Parameter accessing flag (with handshake)' (XB) is on
- 'One slave module changing flag' (X16) is on
- 'Parameter access completion flag' (X11) is off

Precautions

■Parameter setting

Parameters cannot be set in the following cases.

- When an error occurs in the AnyWireASLINK system (Example: Short circuit, 24VDC external power supply voltage drop)
- Within approximately five seconds after the AnyWireASLINK system is powered on or system is reset
- While 'AnyWireASLINK version compatibility inspection executing flag' (XD) is on
- While 'Adjustment mode executing flag' (XF) is on
- When the automatic address detection is in progress (While 'Automatic address detection flag' (X14) is on)
- When the same address used check is in progress (While 'Overlap address inspection flag' (X15) is on)
- When the parameter access is in progress (While 'Parameter access request command for the slave module' (Y10), 'Parameter batch read command for the slave module' (Y11), or 'Parameter batch write command for the slave module' (Y12) is on)
- When any of the following errors has occurred

Error code	Error description
0CC8H	Transmission cable voltage drop error
0CC9H	DP/DN short error
0CCBH	24V/DP short error
1867H	EEPROM access error
3064H	RJ51AW12AL hardware failure
3065H	
3066H	
3068H	CPU module stop error (IORSTL signal detection)
3069H	System error (NMI signal detection)
306BH	CPU module error (ITERR signal detection)
306CH	ASIC access error (library I/F function access error)

■Parameter reading and writing

- When parameter read or write is in progress, 'Parameter access completion flag' (X11) turns off. Refer to the section describing the parameter access timing, and adjust the access timing. (☞ Page 38 Check of the parameter access completion)
- While the parameters are being read or written, do not execute re-access to the parameters, automatic address detection, same address used check, or AnyWireASLINK version compatibility inspection.

■Parameter access, parameter batch read, and parameter batch write

- These operations cannot be performed to a slave module whose ID has not been registered in the RJ51AW12AL.
- Remove a same ID used error or a no ID setting error of the slave module. Then perform the operations.
- Because parameter batch write updates all parameters of target slave modules, all parameters to which no changes are made need to be set correctly. Be sure to execute parameter batch read right before executing parameter batch write. Then, import the latest parameters and execute parameter batch write. Executing parameter batch write without executing parameter batch read will result in a malfunction.

■Others

- When the automatic address detection is executed, the parameter batch read is executed simultaneously.
- Note that the RJ51AW12AL may communicate with a slave module and output parameters even if no parameters are set.
- When Y10, Y11, and Y12 are turned on at the same time, the order of priority will be Y10 > Y11 > Y12.

1.13 Easy Replacement function for One Slave Module

When the slave module is replaced with the one of the same type, this function automatically sets the address and the device parameter with no need of using an address writer.

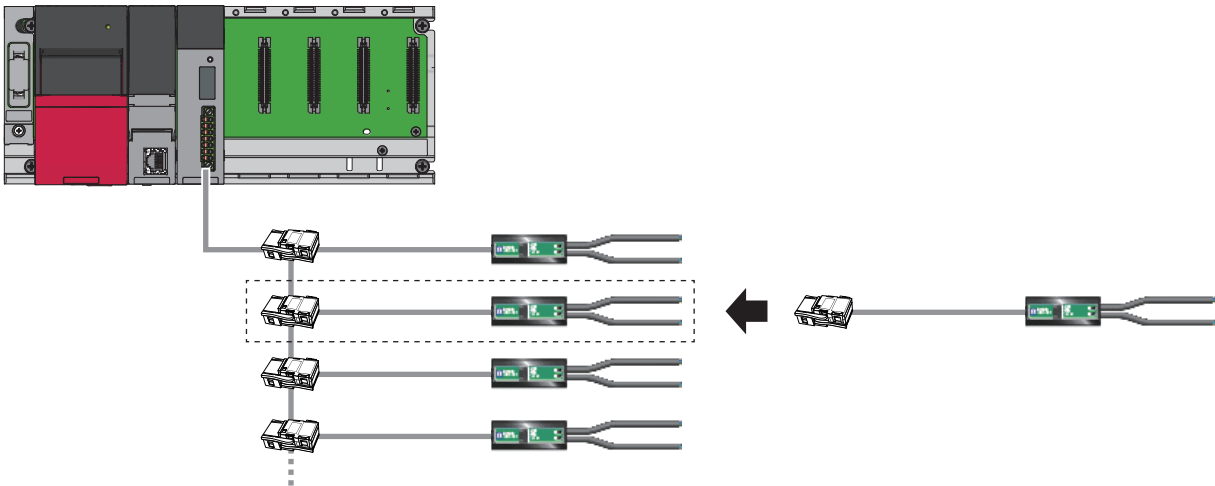

Restriction

When using this function, check the production information of the RJ51AW12AL. (Page 133 Added or Changed Functions)

After the slave module replacement, the RJ51AW12AL checks that the new slave module has the same type as the old one. When the types of the old and new slave modules match, the following backup data is restored to the new slave module so that the new slave module can be used.*1

- Module ID
- Device parameters 1 to 19 (parameter value detected by the automatic address detection)

*1 Parameter information acquired through parameter access cannot be restored.

Applicable slave module

For slave modules that support this function, consult Anywire Corporation.

Point

Replace the slave module with the one that meets the following conditions.

- Unused slave module of which address and device parameter are not changed
- Slave module to which the teaching is not executed

Use conditions

The following conditions must be met to use this function.

- The RJ51AW12AL supports this function. (☞ Page 133 Added or Changed Functions)
- The new slave module supports this function.
- The automatic address detection is performed correctly while "Easy replacement enable/disable setting for one slave module" is set to "0: Enable" in the module parameter of the RJ51AW12AL. (Parameter information of the slave module is stored in the RJ51AW12AL.)
- Other slave modules than the one to be replaced have no errors.
- Slave modules with no IDs assigned are not registered.
- 'Adjustment mode executing flag' (XF) turns off.

Operating procedure

1. Turn off the 24VDC external power supply connected to the RJ51AW12AL.

Voltage of the transmission cable drops, and 'Transmission cable voltage drop error' (X3) turns off and on.

2. Disconnect the slave module to be replaced. (Two or more slave modules cannot be replaced at the same time.)

3. Connect an unused slave module of the same type. (☞ Page 41 Applicable slave module)

4. Turn on the 24VDC external power supply connected to the RJ51AW12AL.

A DP/DN disconnection error occurs, and 'DP/DN disconnection error' (X4) turns off and on.

5. 'One slave module changing flag' (X16) turns off and on, and the backup data is restored from the RJ51AW12AL.

6. After the backup data is restored, 'One slave module changing flag' (X16) turns on and off, and 'Slave module replacement completion flag' (X17) turns off and on.

Simultaneously, the error status of the RJ51AW12AL is cleared. (As with turning off and on 'Error flag clear command' (Y0) (☞ Page 93 Error flag clear command: Y0))

7. Approximately five seconds later, 'Slave module replacement completion flag' (X17) turns on and off, and the replacement of the slave module is completed.

Point

- Every time "Easy replacement enable/disable setting for one slave module" is changed from "1: Disable" to "0: Enable", execute the automatic address detection. Executing the automatic address detection with the easy one-device replacement enabled stores the device parameters of the slave module to the RJ51AW12AL.
- Unless the automatic address detection is executed, the replacement of the slave module will not be completed successfully, and a malfunction may be caused.
- The easy replacement function for one slave module stops if an error occurs in midstream. Eliminate the error cause, and follow the procedures from step 1 again.

Timing of slave module replacement

The following shows the timing up until the completion of the slave module replacement.

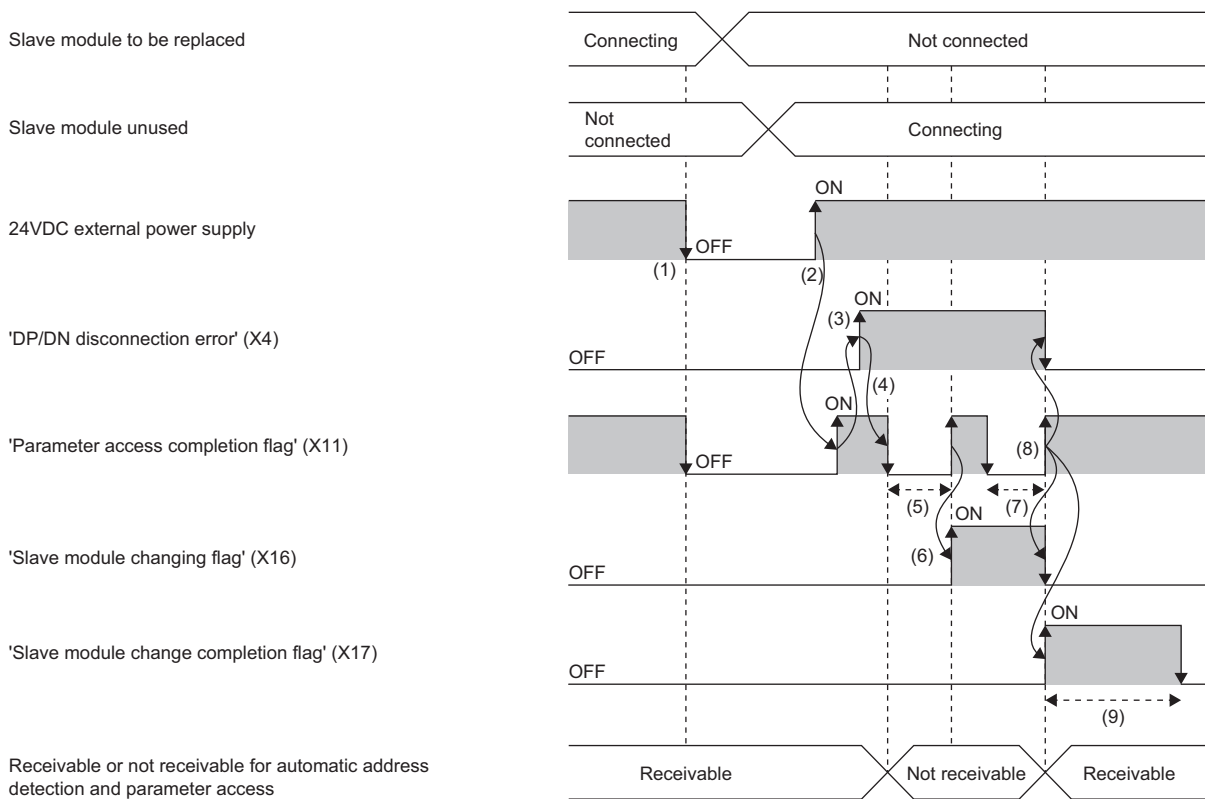

(1) Turn off the 24VDC external power supply connected to the RJ51AW12AL.

(2) When an unused slave module is mounted and the 24VDC external power supply is turned on, 'Parameter access completion flag' (X11) turns off and on.

(3) Check the connection status of the slave modules of which IDs have been registered. In addition, 'DP/DN disconnection error' (X4) turns off and on.

(4) Connection status is checked to see that an unused slave module is connected. In addition, 'Parameter access completion flag' (X11) turns on and off.

(5) The RJ51AW12AL verifies the model name of the new slave module against that of the old one during the parameter access processing.

(6) The moment the parameter access processing has been completed, 'Parameter access completion flag' (X11) and 'One slave module changing flag' (X16) turn off and on.

(7) 'Parameter access completion flag' (X11) turns on and off, and the backup data is restored to the new slave module from the RJ51AW12AL.

(8) The statuses of the following input signals change when the backup data is restored. In addition, the error status of the RJ51AW12AL is cleared. (As with turning off and on 'Error flag clear command' (Y0))

- 'Parameter access completion flag' (X11) turns off and on.
- 'One slave module changing flag' (X16) turns on and off.
- 'Slave module replacement completion flag' (X17) turns off and on.

(9) Approximately five seconds later, 'Slave module replacement completion flag' (X17) turns on and off.

1.14 Word Data Start Address Setting Function

This function sets the start address of the word data transmission. Setting the start address shortens the word transmission cycle time.

Unregistered addresses between address 0 and the registered address are accessed during word transmission. Although this access takes extra time for word transmission cycle, setting the number of word data points and transmission start address enhances the efficiency of transmission.

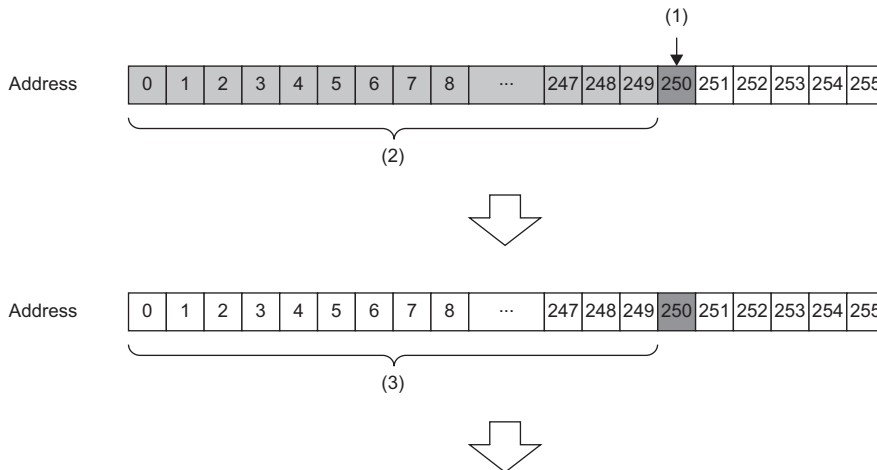

Address

- (1) Registered address (word slave module)
- (2) Access to unregistered addresses existing before the registered address causes extra time for word transmission cycle. (Number of word data points setting: 512 words (256 input words/256 output words))
- (3) When the word data points setting is 2 words (1 input word/1 output word) and the word data transmission start address is set to 250, the address targeted for access will be 250 only.

Restriction

When using this function, check the production information of the RJ51AW12AL. (Page 133 Added or Changed Functions)

Point

This function can be used for word data only. This function does not affect the target input and output addresses of bit data.

Setting method

Set this function in "Word data points setting" of "Basic setting". (Page 51 Word data point setting)

Precautions

An address exceeding the specified number of word data points cannot be set to "Word data points setting".

1.15 AnyWireASLINK Version Compatibility Inspection Function

This function checks whether slave modules not supporting word data are connected to the RJ51AW12AL or not.

Restriction

When using this function, check the production information of the RJ51AW12AL. ( Page 133 Added or Changed Functions)

Operating procedure

1. Perform either of the following operations.
 - Turn off and on 'AnyWireASLINK version compatibility inspection command' (YD).
 - While holding down the SET switch on the RJ51AW12AL, reset the CPU module or power off and on the system.
2. The status will be changed as follows, and the AnyWireASLINK version compatibility inspection will start.
 - 'AnyWireASLINK version compatibility inspection executing flag' (XD) turns off and on.
 - 'Parameter access completion flag' (X11) turns on and off.
 - The LINK LED stops flashing and stays on.
3. When the AnyWireASLINK version compatibility inspection completes, the LINK LED stops illuminating and flashes. (The inspection takes approximately 15 seconds.)

Point

- The AnyWireASLINK transmission stops when the AnyWireASLINK version compatibility inspection starts.
- Error flags are cleared before the AnyWireASLINK version compatibility inspection starts. (As with turning off and on 'Error flag clear command' (Y0))

How to check the error status

If an AnyWireASLINK version compatibility inspection error exists after the inspection, the status will be as follows.

Item	Description
'AnyWireASLINK version compatibility inspection error' (X8)	Turns off and on.
'Latest error code storage area' (Un\G10256)	The relevant error code is stored.
'Latest error ID storage area' (Un\G10257)	0FFFH is stored.
'Event code for sub information area' (Un\G12096)	The relevant event code is stored.
'Sub information area' (Un\G12097 to Un\G12224)	The bits corresponding to target IDs of slave modules having an error are turned on.
ALM LED	Turns on.

The following are the probable causes of the AnyWireASLINK version compatibility inspection error. Identify the error cause and take appropriate actions.

- The number of connected slave modules exceeds the limit.
- Parameter access fails on one or more slave modules.
- A slave module not supporting word data is connected to the RJ51AW12AL.

Clear the AnyWireASLINK version compatibility inspection error, and start the inspection again.

Precautions

■Conditions for performing the AnyWireASLINK version compatibility inspection

All the following conditions must be met to perform the AnyWireASLINK version compatibility inspection.

- The number of word data points is set to 2 words (1 input word/1 output word) or more.
- No errors exists on the RJ51AW12AL.
- 'Adjustment mode executing flag' (XF) is off.
- 'Parameter access completion flag' (X11) is on.
- 'Automatic address detection flag' (X14), 'Overlap address inspection flag' (X15), and 'One slave module changing flag' (X16) are off.

Timing of the AnyWireASLINK version compatibility inspection

The following shows the timing of each step in the AnyWireASLINK version compatibility inspection.

■When the inspection is executed by 'AnyWireASLINK version compatibility inspection command' (YD)

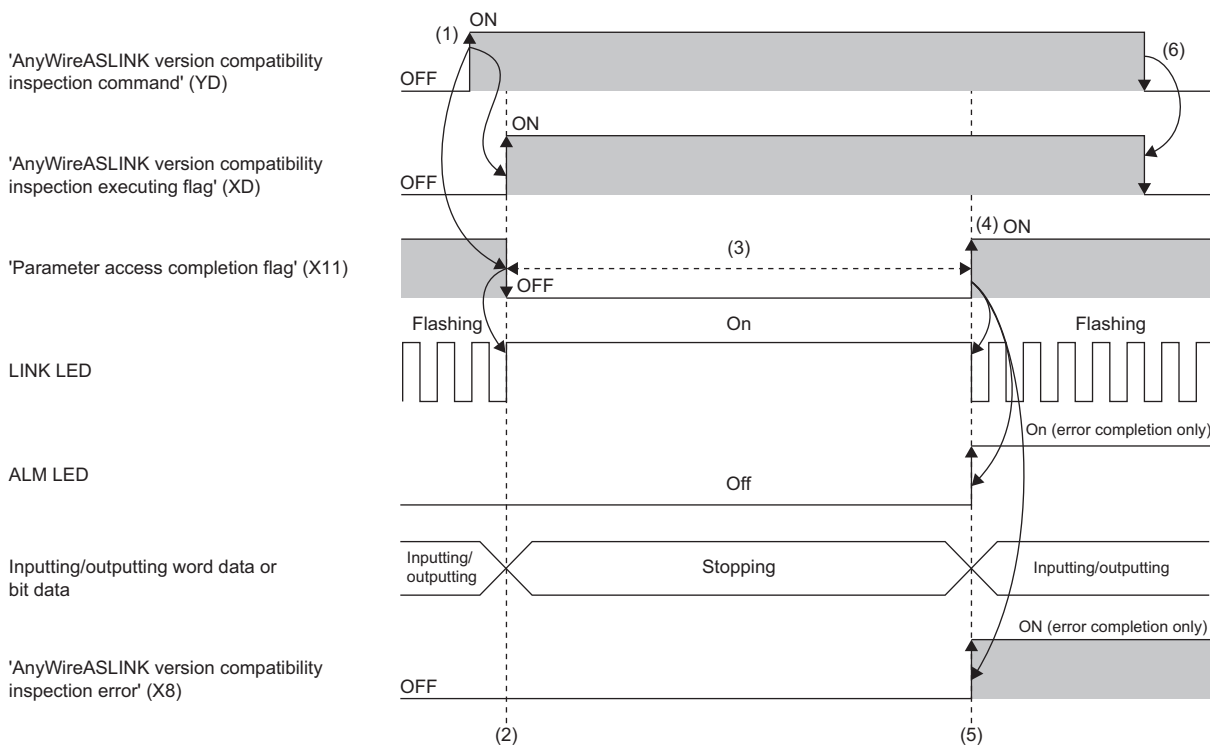

- (1) When 'AnyWireASLINK version compatibility inspection command' (YD) is turned off and on, 'AnyWireASLINK version compatibility inspection executing flag' (XD) turns off and on, and 'Parameter access completion flag' (X11) turns on and off.
- (2) The AnyWireASLINK version compatibility inspection starts.
- (3) Parameter access is in progress.
- (4) 'Parameter access completion flag' (X11) turns off and on upon completion of the parameter access.
- (5) The AnyWireASLINK version compatibility inspection completes.
- (6) When 'AnyWireASLINK version compatibility inspection command' (YD) is turned on and off, 'AnyWireASLINK version compatibility inspection executing flag' (XD) turns on and off.

■ When the inspection is executed by the SET switch

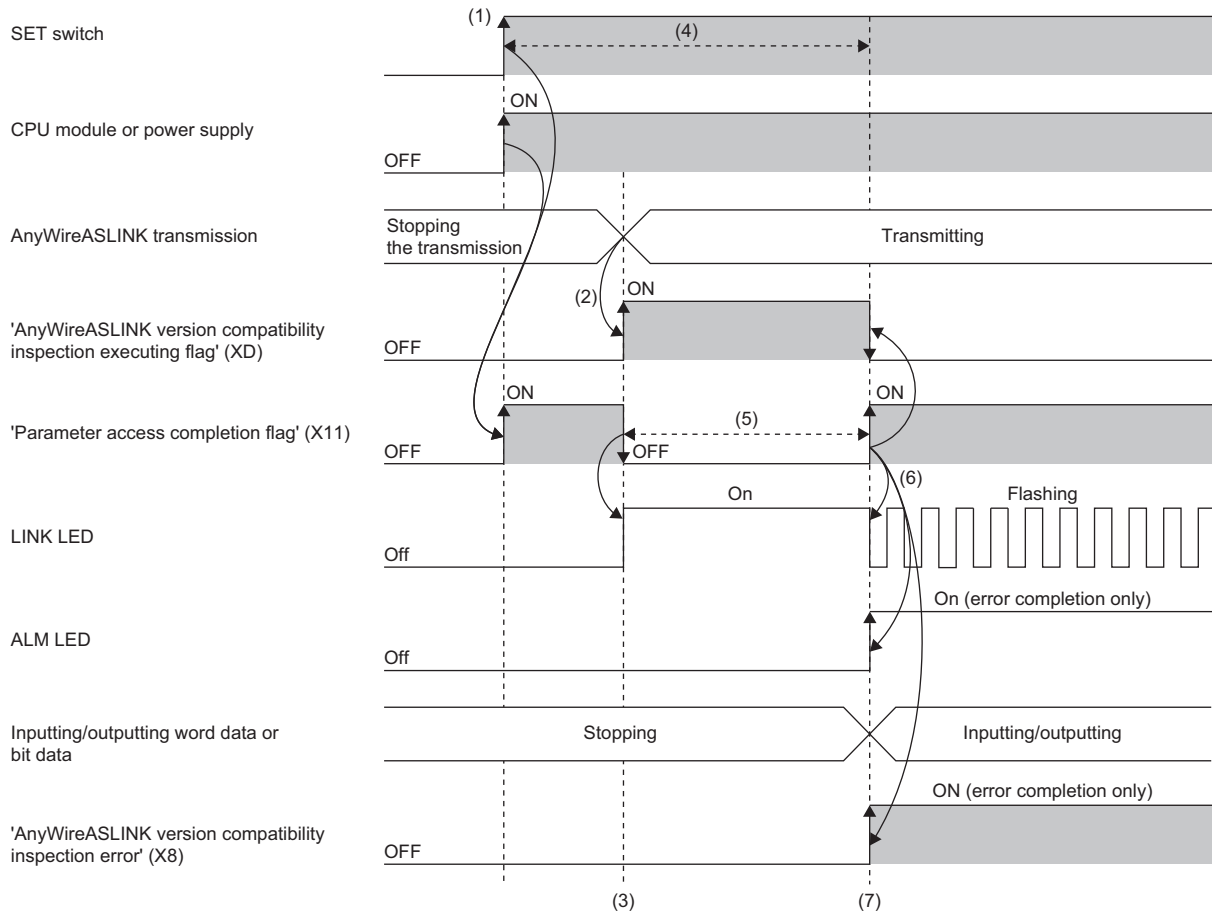

- (1) While holding down the SET switch, reset the CPU module or power off and on the system. (Hold down the SET switch for one second or longer.)
- (2) When the AnyWireASLINK transmission starts, 'AnyWireASLINK version compatibility inspection executing flag' (XD) turns off and on, and 'Parameter access completion flag' (X11) turns on and off.
- (3) The AnyWireASLINK version compatibility inspection starts.
- (4) During this period, the operation is not affected by the on/off status of the switch or the command.
- (5) Parameter access is in progress.
- (6) 'Parameter access completion flag' (X11) turns off and on upon completion of the parameter access.
- (7) The AnyWireASLINK version compatibility inspection completes.

Point

When 'AnyWireASLINK version compatibility inspection command' (YD) is turned off and on during AnyWireASLINK version compatibility inspection, 'AnyWireASLINK version compatibility inspection executing flag' (XD) does not turn on and off even if AnyWireASLINK version compatibility inspection is completed. When 'AnyWireASLINK version compatibility inspection command' (YD) is turned on and off, 'AnyWireASLINK version compatibility inspection executing flag' (XD) turns on and off.

2 PARAMETER SETTINGS

This chapter describes the parameter setting required for the RJ51AW12AL.

2.1 Parameter Setting Procedure

1. Add the RJ51AW12AL to an engineering tool.

 [Navigation window] ⇒ [Parameter] ⇒ [Module Information] ⇒ Right click ⇒ [Add New Module]

2. The parameter setting includes a basic setting and refresh setting. Select the settings in the tree and set the items in the following window.

 [Navigation window] ⇒ [Parameter] ⇒ [Module Information] ⇒ [RJ51AW12AL] ⇒ [Module Parameter]

3. Write the setting to the CPU module with the engineering tool.

 [Online] ⇒ [Write to PLC]

4. Reset the CPU module or power off and on the system to apply the setting.

2.2 Basic Setting

Set the number of transmission points of the RJ51AW12AL and others.

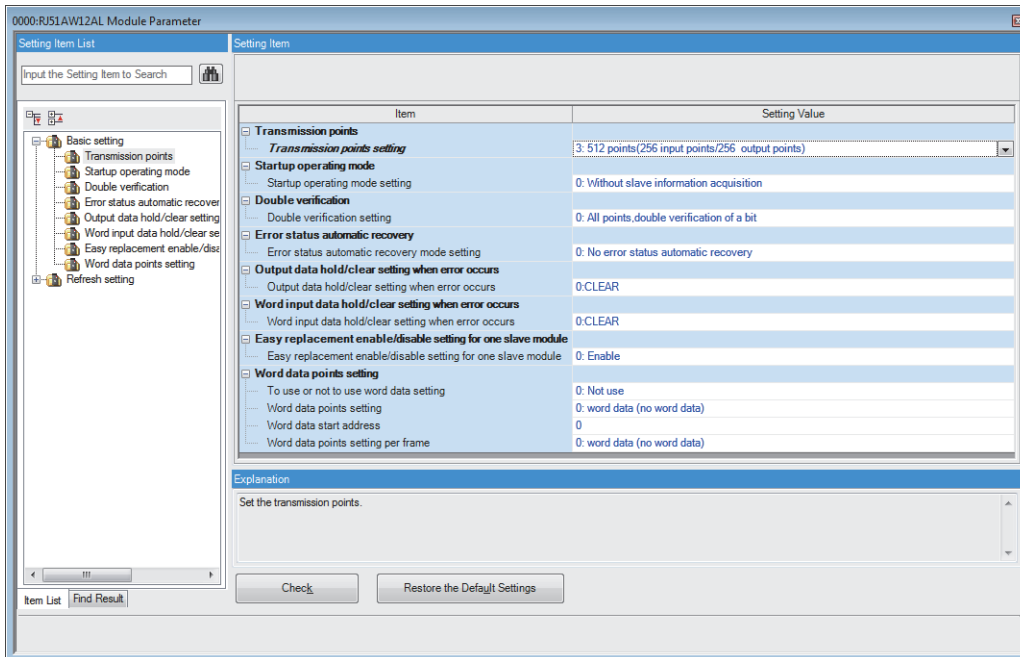

2

Bit data setting

Set the number of bit data transmission points of AnyWireASLINK.

Item	Description	Setting range
Transmission points setting	Set the number of bit data points. The transmission cycle time is determined based on the specified number of bit data points. (Page 111 Transmission cycle time)	<ul style="list-style-type: none"> 0: 64 points (32 input points/32 output points) 1: 128 points (64 input points/64 output points) 2: 256 points (128 input points/128 output points) 3: 512 points (256 input points/256 output points) 10: 0 points (0 input points/0 output points) (Default: 3: 512 points (256 input points/256 output points))

Startup operating mode setting

Set whether to read the parameters of slave modules at start-up of the RJ51AW12AL.

Item	Description	Setting range
Startup operating mode setting	Set the operation mode at start-up.	<ul style="list-style-type: none"> 0: Without slave information acquisition 1: Get slave Information acquisition (Default: 0: Without slave information acquisition)

Bit data double verification setting

Set the double verification of the bit data of the RJ51AW12AL.

Item	Description	Setting range
Double verification setting	Set the bit data double verification mode. (☞ Page 19 Double Verification)	<ul style="list-style-type: none"> • 0: All points, double verification of a bit • 1: Double verification of the 16bit(word) until the 1st word • 2: Double verification of the 16bit(word) until the 2nd word • 3: Double verification of the 16bit(word) until the 3rd word • 4: Double verification of the 16bit(word) until the 4th word • 5: Double verification of the 16bit(word) until the 5th word • 6: Double verification of the 16bit(word) until the 6th word • 7: Double verification of the 16bit(word) until the 7th word • 8: Double verification of the 16bit(word) until the 8th word • 9: Double verification of the 16bit(word) until the 9th word • 10: Double verification of the 16bit(word) until the 10th word • 11: Double verification of the 16bit(word) until the 11th word • 12: Double verification of the 16bit(word) until the 12th word • 13: Double verification of the 16bit(word) until the 13th word • 14: Double verification of the 16bit(word) until the 14th word • 15: Double verification of the 16bit(word) until the 15th word • 16: All points, double verification of the 16bit(word) (Default: 0: All points, double verification of a bit)

Error status automatic recovery setting

Set whether to automatically recover the RJ51AW12AL from the error status.

Item	Description	Setting range
Error status automatic recovery mode setting	Set the error status automatic recovery mode. (☞ Page 31 Error Status Automatic Recovery Function)	<ul style="list-style-type: none"> • 0: No error status automatic recovery • 1: Error status automatic recovery (Default: 0: No error status automatic recovery)

Holding/clearing output data against error setting

Set the slave module to hold or clear the output data when the RJ51AW12AL detects the following errors.

- CPU module stop error (IORSTL signal detection)
- System error (NMI signal detection)
- CPU module error (ITERR signal detection)
- ASIC access error (library I/F function access error)

Item	Description	Setting range
Output data hold/clear setting when error occurs	Set whether to hold or clear the output data when an error occurs.	<ul style="list-style-type: none"> • 0: CLEAR • 1: HOLD (Default: 0: CLEAR)

Holding/clearing word output data against error setting

Set the word slave module to hold or clear the input data when a disconnection is detected.

Item	Description	Setting range
"Word input data hold/clear setting when error occurs	Set whether to hold or clear the word input data when a disconnection is detected.	<ul style="list-style-type: none"> • 0: CLEAR • 1: HOLD (Default: 0: CLEAR)

Enabling/disabling the easy replacement setting for one slave module

Set whether to enable or disable easy replacement setting for one slave module.

Item	Description	Setting range
Easy replacement enable/disable setting for one slave module	Enable or disable easy replacement setting for one slave module.	<ul style="list-style-type: none"> • 0: Enable • 1: Disable (Default: 0: Enable)

Word data point setting

Set the number of word data points to be used.

Item	Description	Setting range
To use or not to use word data setting	Set whether to use the word data.	<ul style="list-style-type: none"> • 0: Not use • 1: Use (Default: 0: Not use)
Word data points setting	Set the number of word data points to be used.*1 Because the number of word data points should be the same between input and output, set the number of word data points to that of input or output, whichever is larger.	<ul style="list-style-type: none"> • 0: word data (no word data) • 1: 2 words (1 input word, 1 output word) • 2: 4 words (2 input words, 2 output words) • 4: 8 words (4 input word, 4 output word) • 8: 16 words (8 input word, 8 output word) • 16: 32 words (16 input word, 16 output word) • 32: 64 words (32 input words, 32 output words) • 64: 128 words (64 input words, 64 output words) • 128: 256 words (128 input words, 128 output words) • 256: 512 words (256 input words, 256 output words) • 512: 1024 words (512 input words, 512 output words) (Default: 0: word data (no word data))
Word data start address	Set the word data transmission start address.*1	0 to 511 (Default: 0)
Word data points setting per frame	Set the number of points to be stored in one frame of word transmission of AnyWireASLINK.*1	<ul style="list-style-type: none"> • 0: word data (no word data) • 1: 2 words (1 input word, 1 output word) • 2: 4 words (2 input words, 2 output words) • 3: 8 words (4 input words, 4 output words) • 4: 16 words (8 input words, 8 output words) • 5: 32 words (16 input words, 16 output words) (Default: 0: word data (no word data))

*1 This item can be set when "To use or not to use word data setting" is set to "1: Use".

Point 

When the word data is used, slave modules not supporting word data stops operation and disables the ID registration by the automatic address detection.

Slave modules not supporting word data can be identified by the AnyWireASLINK version compatibility inspection. ( Page 45 AnyWireASLINK Version Compatibility Inspection Function)

2.3 Refresh Setting

Setting method

Set buffer memory areas of the RJ51AW12AL to refresh.

This refresh setting eliminates the needs for reading or writing with a program.

1. Start a module parameter.

 [Navigation window] ⇒ [Parameter] ⇒ [Module Information] ⇒ [RJ51AW12AL] ⇒ [Module Parameter] ⇒ [Refresh setting]

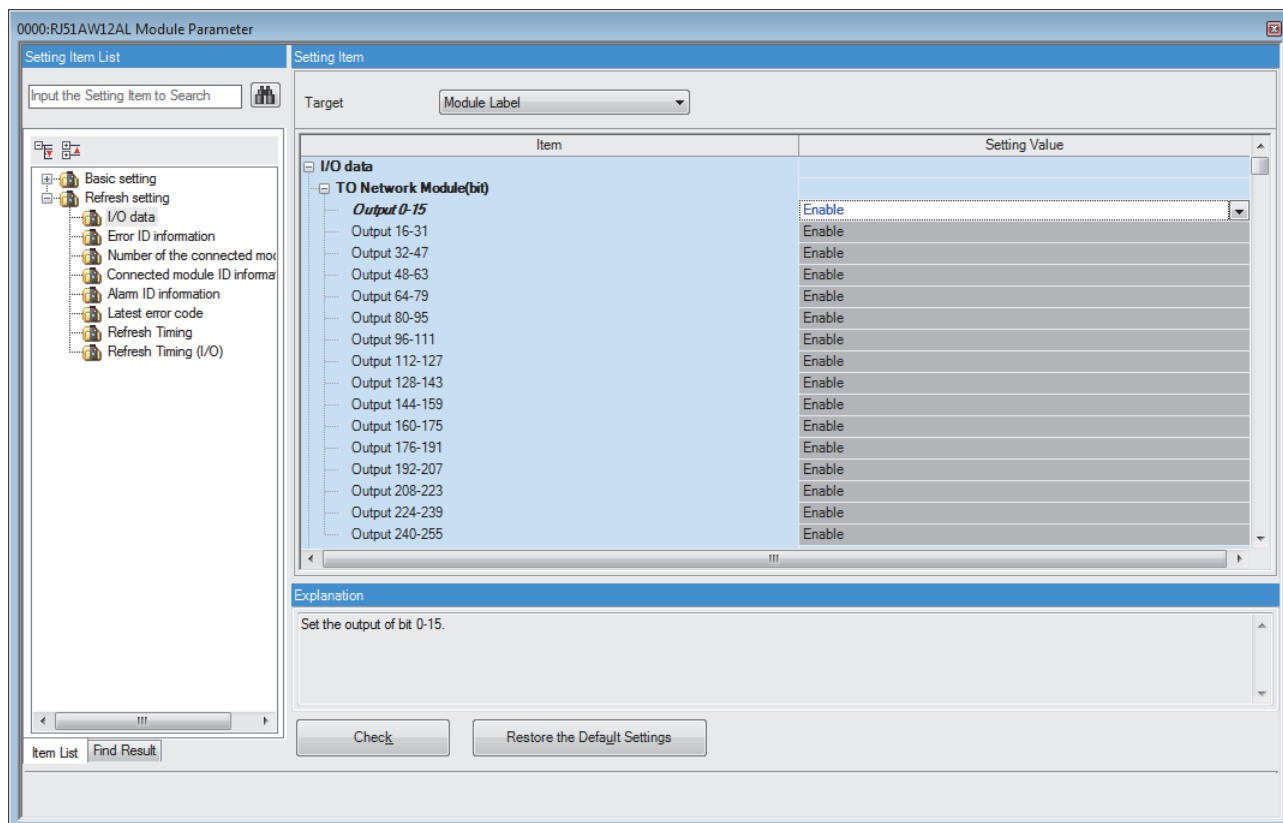

2. Click "Target" and set a refresh target.

- When "Target" is "Module Label"

Enable or disable "Output 0-15" to enable or disable the refresh.

- When "Target" is "Refresh Data Register (RD)"

Set a start device in "Start Device Name" to set transfer destinations of all the items automatically.

- When "Target" is "Device"

Double-click the item to set and enter a refresh target device.

3. Click "Refresh Timing", and set the refresh timing.

Set "Refresh Timing" to "At the Execution Time of END Instruction" or "At the Execution Time of Specified Program".

If "At the Execution Time of Specified Program" is selected, double-click "Refresh group [n] (n: 1-64)", and select the desired number from 1 to 64.

Point

When refresh is enabled, the values of refresh targets become effective at the refresh timing set with an engineering tool. At this time, buffer memory areas are overwritten with the values of the refresh targets. To change the values of the buffer memory areas to be refreshed, create a program that modifies module labels and device values of the refresh targets.

2.4 Refresh Processing Time

The refresh processing time [μs] is an element of the scan time of the CPU module. For the scan time, refer to the following.

 MELSEC iQ-R CPU Module User's Manual (Application)

The following shows the refresh processing time [μs] taken for refresh settings.

- Refresh processing time [μs] = Refresh read (refresh of transfer to the CPU) time + Refresh write (refresh of transferred to intelligent function modules) time

The refresh read time and refresh write time vary depending on refresh targets.

When the refresh target is a module label or refresh data register (RD)

The following shows the refresh read time and refresh write time when a CPU module is used.

Classification	Refresh processing time
Refresh read time	21.8 μs
Refresh write time	0.16 μs

When the refresh target is a specified device

The refresh read time and refresh write time are calculated according to the number of refresh-target items and the number of the items to be transferred (words). For the calculation method, refer to the following.

 MELSEC iQ-R CPU Module User's Manual (Application)

2.5 Slave Module Address Setting

Setting a start number of the address assigned for data communication is required for slave modules.

An address can be written to a slave module or the address assigned to a slave module can be read through infrared communications using an address writer (manufactured by Anywire Corporation).

For details, refer to the manual of the address writer.

■ Image of address read/write

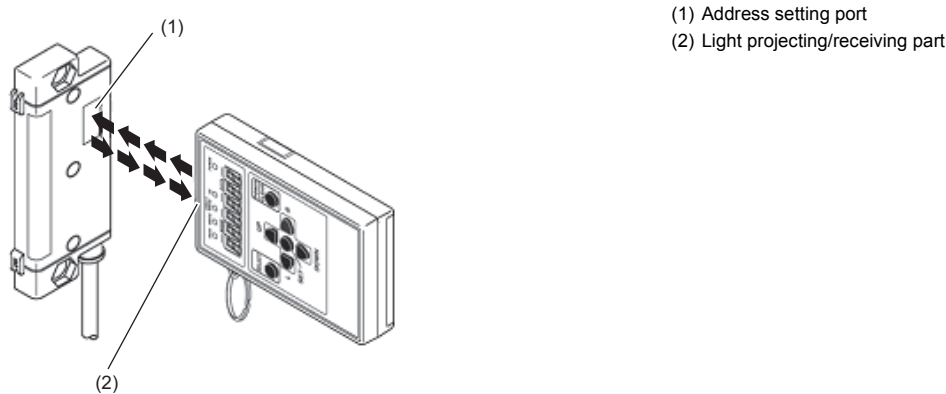

Point

- Addresses cannot be read or written using the address writer unless the power is supplied to the slave module.
- When making the settings related to the word transmission function using the address writer, check the supported models or versions.

Address setting

Set the address of each slave module to assign the slave module to the buffer memory area.

Address means the start bit or word of the memory area occupied by the slave module, which is set using a decimal number.

The buffer memory area corresponding to the number of slave module points is occupied from the specified address.

The number of occupied points differs depending on the slave module. In addition, the same buffer memory area cannot be occupied by different slave modules.

For details, refer to the following.

📖 Manual of the slave module used (manufactured by Anywire Corporation)

Address and ID

The following table shows the relationship between address and ID.

Model		Address	ID
Bit type	Output slave module	0 to 254	0000H to 00FEH
	Input slave module		0200H to 02FEH
	I/O combined slave module		
Word type	Output slave module	0 to 510	0400H to 05FEH
	Input slave module		0600H to 07FEH
	I/O combined slave module		

When data is written to the slave module, the data is written in the range of the above address (not in the range of the ID).

■ Slave module that uses both bit transmission and word transmission

The following table shows the address and ID of the slave module that uses both bit transmission and word transmission.

Item	Description
Address	Use word address on slave modules that use both bit transmission and word transmission. When a word address is set, the same address will be applied to the bit address.*1 For example, when the word address is set to 120, the bit address is set to 120.
ID	ID is assigned as a word address. For example, when address 120 (0078H) is set on the word input slave module, the ID is set to 0678H.

*1 Slave modules for which bit address is selected do not perform word transmission. For the operation of slave modules for which bit address is selected, refer to the following.

 Manual of the slave module used (manufactured by Anywire Corporation)

Address setting example

■ Assignment by 2-point bit slave module only

When 0 is set for the input slave module address, and 0 and 2 for the output slave module address, bits are occupied as follows.

- Buffer memory address of the input slave module

Buffer memory address	Bit No.															
	15	14	13	12	11	10	9	8	7	6	5	4	3	2	1	0
Un\G0	15	14	13	12	11	10	9	8	7	6	5	4	3	2	1	0

Areas occupied by address 0 of the 2-point slave module: Un\G0.0, Un\G0.1

- Buffer memory address of the output slave module

Buffer memory address	Bit No.															
	15	14	13	12	11	10	9	8	7	6	5	4	3	2	1	0
Un\G4096	15	14	13	12	11	10	9	8	7	6	5	4	3	2	1	0

Areas occupied by address 0 of the 2-point slave module: Un\G4096.0, Un\G4096.1

Areas occupied by address 2 of the 2-point slave module: Un\G4096.2, Un\G4096.3

■Mixed assignment by 2-point bit slave module and 1-point bit slave module

When 0, 2, and 3 are set for the input slave module address, and 0, 2, and 3 for the output slave module address, bits are occupied as follows.

- Buffer memory address of the input slave module

Buffer memory address	Bit No.															
	15	14	13	12	11	10	9	8	7	6	5	4	3	2	1	0
Un\G0	15	14	13	12	11	10	9	8	7	6	5	4	3	2	1	0

Areas occupied by address 0 of the 2-point slave module: Un\G0.0, Un\G0.1

Area occupied by address 2 of the 1-point slave module: Un\G0.2

Areas occupied by address 3 of the 2-point slave module: Un\G0.3, Un\G0.4

- Buffer memory address of the output slave module

Buffer memory address	Bit No.															
	15	14	13	12	11	10	9	8	7	6	5	4	3	2	1	0
Un\G4096	15	14	13	12	11	10	9	8	7	6	5	4	3	2	1	0

Areas occupied by address 0 of the 2-point slave module: Un\G4096.0, Un\G4096.1

Area occupied by address 2 of the 1-point slave module: Un\G4096.2

Areas occupied by address 3 of the 2-point slave module: Un\G4096.3, Un\G4096.4

■Assignment by 2-word word slave module only

When 0 is set for the input slave module address, and 0 and 2 for the output slave module address, words are occupied as follows.

- Buffer memory address of the input slave module

Buffer memory address	Word No.
Un\G512	0
Un\G513	1
Un\G514	2
Un\G515	3
Un\G516	4

Areas occupied by address 0 of the 2-word slave module: Un\G512, Un\G513

- Buffer memory address of the output slave module

Buffer memory address	Word No.
Un\G4608	0
Un\G4609	1
Un\G4610	2
Un\G4611	3
Un\G4612	4

Areas occupied by address 0 of the 2-word slave module: Un\G4608, Un\G4609

Areas occupied by address 2 of the 2-word slave module: Un\G4610, Un\G4611

Values are correctly stored in the buffer memory only when the number of points is set to 8 words (4 input words/4 output words) or larger.

Precautions

- A slave module address is not deleted even when the power supply of a programmable controller or a 24VDC external power supply is turned off. The address is retained until a new address is set when a system is configured.
- In the address setting, ensure that the address occupied by the slave module does not exceed the number of transmission points set in the RJ51AW12AL. For the operation mode setting of the RJ51AW12AL, refer to the following.

☞ Page 49 Bit data setting

Ex.

When "Transmission points setting" is set to "0: 64 points (32 input points/32 output points)", the effective address range is between 0 and 31.

If the address is set to 32 or larger, the slave module does not communicate I/O data.

When "Word data points setting" is set to "4: 8 words (input 4 words, output 4 words)", the effective address range is between 0 and 3.

If the address is set to 4 or larger, the slave module does not communicate I/O data.

- Do not use the following values when writing the address of the slave module. Doing so will cause a No ID setting error.

Model	Address
Bit slave module	255, 511
Word slave module	511

2.6 Automatic Address Detection Function

Automatic address detection refers to a function that stores the IDs (addresses) of the connected slave modules in the EEPROM of the RJ51AW12AL.

Pressing the SET switch on the RJ51AW12AL enables this function and enables the RJ51AW12AL to detect and store IDs (addresses) of connected slave modules.

The ID (address) information stored in the EEPROM is held even when the power is turned off. However, information about unset IDs, the same IDs, and the parameter information of each slave module are not held.

Whenever starting the system or changing the system configuration, set the correct addresses to all the slave modules and execute the automatic address detection.

Executing the automatic address detection

To execute the automatic address detection, use the SET switch or 'Automatic address detection command' (Y1).

Using the SET switch

1. Check that all of the slave modules are operating normally.
2. Keep pressing the SET switch on the RJ51AW12AL until the SET LED turns on.
At this time, 'Automatic address detection flag' (X14) turns on.
3. When the SET LED flashes for a while and turns off, the ID (address) has been stored.
4. When 'Automatic address detection flag' (X14) turns off, the automatic address detection is completed.

Using 'Automatic address detection command' (Y1)

1. Check that all of the slave modules are operating normally.
2. Turn on and off 'Automatic address detection command' (Y1).
At this time, 'Automatic address detection flag' (X14) turns on.
3. When the SET LED flashes for a while and turns off, the ID (address) has been stored.
4. When 'Automatic address detection flag' (X14) turns off, the automatic address detection is completed.

Precautions

■ Situations in which automatic address detection cannot be executed

Automatic address detection cannot be executed in the following cases.

- When an error occurs in the AnyWireASLINK system (Example: Short circuit, 24VDC external power supply voltage drop)
- Within approximately five seconds after the AnyWireASLINK system is powered on or system reset recovery
- While 'Adjustment mode executing flag' (XF) is on
- While 'Parameter access completion flag' (X11) is off
- When automatic address detection is in progress (While 'Automatic address detection flag' (X14) is on)
- When the same address used check is in progress (While 'Overlap address inspection flag' (X15) is on)
- When the easy replacement setting for one slave module is in progress (While 'One slave module changing flag' (X16) is off)
- When the parameter access is in progress (While 'Parameter access request command for the slave module' (Y10), 'Parameter batch read command for the slave module' (Y11), or 'Parameter batch write command for the slave module' (Y12) is on)
- When any of the following errors has occurred

Error code	Error description
0CC8H	Transmission cable voltage drop error
0CC9H	DP/DN short error
0CCBH	24V/DP short error
1867H	EEPROM access error
3064H	RJ51AW12AL hardware failure
3065H	
3066H	
3068H	CPU module stop error (IORSTL signal detection)
3069H	System error (NMI signal detection)
306BH	CPU module error (ITERR signal detection)
306CH	ASIC access error (library I/F function access error)

■ Situations in which automatic address detection is required

Execute automatic address detection in the following cases.

- When starting the system operation (when all of the slave modules are connected and operating normally)
- When adding a slave module after starting the system operation
- When removing a slave module after starting the system operation
- When changing the address of a slave module after starting the system operation
- When enabling easy replacement setting for one slave module
- When changing device parameters of a slave module or restoring data with the data backup/restoration after enabling easy replacement setting for one slave module

■ Check after execution of automatic address detection

After executing automatic address detection, check that there is no inconsistency between the actual system configuration and the IDs registered in the RJ51AW12AL, referring to the value stored in 'Number of the IDs of the connected modules' (Un\G9216) and values stored in 'Connected module ID information storage area' (Un\G9217 to Un\G9344).

■ Executing automatic address detection again

Use an address writer to set the ID (address) in a slave module that has the same ID as other slave modules or where an ID is not set. Then execute automatic address detection again.

■ Word slave modules

When the automatic address detection function is executed with a word slave module connected, set the number of word data points in the parameter setting to 2 words (1 input word/1 output word) or larger. (Page 51 Word data point setting)
If the number of word data points is not set, the address is not stored in the EEPROM of the RJ51AW12AL even when the automatic address detection function is executed.

Automatic address detection execution timing

The following shows automatic address detection execution timing.

Turning on 'Automatic address detection command' (Y1)^{*1}
(or long press of the SET switch)

'Automatic address detection flag' (X14)

SET LED

'Overlap address inspection flag' (X15)

'Parameter access completion flag' (X11)

'Parameter access error' (X12)

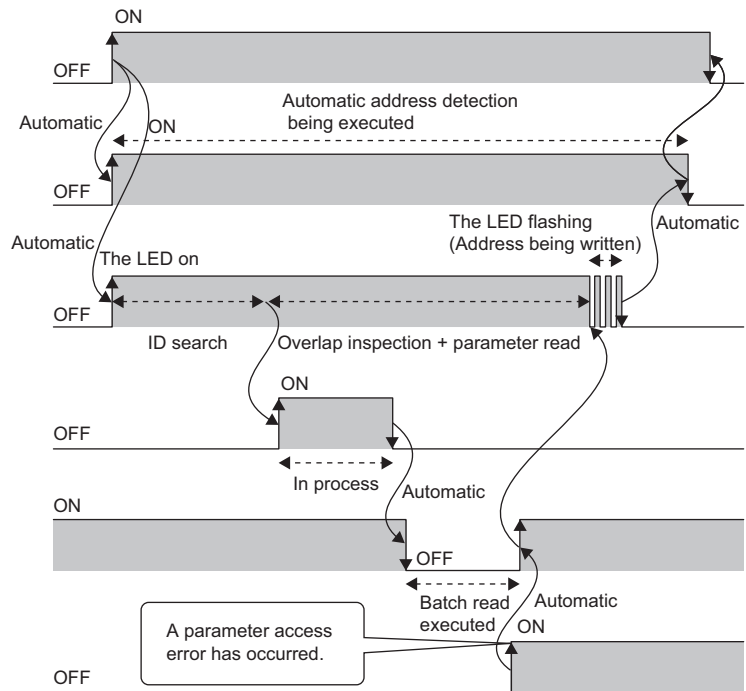

*1 After turning on 'Automatic address detection command' (Y1), check that 'Automatic address detection flag' (X14) is on or check the SET LED status. Then, turn off 'Automatic address detection command' (Y1) with a program.

2.7 Automatic reading of system configuration

Man-hour for setting parameters can be reduced by automatically reading the information of the slave module connected over AnyWireASLINK.

[Navigation window] ⇒ [Parameter] ⇒ [Module Information] ⇒ [RJ51AW12AL] ⇒ [AnyWireASLINK configuration]

2

No.	I/O Type	Address	Model Name	Type	# of Occupied Bit Pts		# of Occupied Word Pts		Bit/Word Mode
					Input	Output	Input	Output	
			RJ51AW12AL	AnyWireASLINK Master Module					
1	Output		B280PB-02U-C1220	ASLINKER-Output Module-non-Isolated(Sink Type)	0	2	0	0	
2	Output		B281PB-02U-CC20	ASLINKER-Output Module-non-Isolated(Sink Type)	0	2	0	0	
3	Input		B280SB-02U-C1220	ASLINKER-Input Module-non-Isolated(Sink Type)	2	0	0	0	
4	Input		B281SB-02U-CC20	ASLINKER-Input Module-non-Isolated(Sink Type)	2	0	0	0	
5	Input		B289SB-01AF-CAS	ASLINKAMP-Input Module-non-Isolated(Fiber Sensor Amplif	1	0	0	0	
6	Input		B289SB-01AF-CAS	ASLINKAMP-Input Module-non-Isolated(Fiber Sensor Amplif	1	0	0	0	
7	Input		B289SB-01AF-CAS	ASLINKAMP-Input Module-non-Isolated(Fiber Sensor Amplif	1	0	0	0	
8	Input		B289SB-01AF-CAM20	ASLINKAMP-Input Module-non-Isolated(Fiber Sensor Amplif	1	0	0	0	

For details on the "AnyWireASLINK configuration" window, refer to the following.

iQ Sensor Solution Reference Manual

3 PROGRAMMING

This chapter describes programming for the RJ51AW12AL.

For communication between the RJ51AW12AL and slave modules, refer to the following.

📖 MELSEC iQ-R AnyWireASLINK Master Module User's Manual (Startup)

3.1 Precautions on Programming

This section describes precautions on programming on the RJ51AW12AL.

Interlock program of automatic address detection

The interlock program described here prevents 'Automatic address detection command' (Y1) from being turned on during a parameter access*¹ or during automatic address detection*¹, allowing proper automatic address detection.

The following shows an interlock program in which the start I/O number of the RJ51AW12AL is assigned to X/Y00 to X/Y1F.

*¹ Indicates that 'Parameter access completion flag' (X11) is off or 'Automatic address detection flag' (X14) is on.

Ex.

Interlock example

Classification	Label name	Description	Device								
Module label	RJ51AW12AL_1.bModuleREADY	Module READY	X0								
	RJ51AW12AL_1.bDP_DNShortError	DP/DN short error	X1								
	RJ51AW12AL_1.b24V_DPShortError	24V/DP short error	X2								
	RJ51AW12AL_1.bTransmissionCableVoltageDdropError	Transmission cable voltage drop error	X3								
	RJ51AW12AL_1.bPalameterAccessCompletionFlag	Parameter access completion flag	X11								
	RJ51AW12AL_1.bAutomaticAddressDetectionFlag	Automatic address detection flag	X14								
	RJ51AW12AL_1.bOverlapAddressInspectionFlag	Overlap address inspection flag	X15								
	RJ51AW12AL_1.bAutomaticAddressDetectionCommand	Automatic address detection command	Y1								
Label to be defined	Define global labels as shown below:										
	<table border="1"> <thead> <tr> <th>Label Name</th> <th>Data Type</th> <th>Class</th> <th>Assign (Device/Label)</th> </tr> </thead> <tbody> <tr> <td>InterlockStart</td> <td>Bit</td> <td>VAR_GLOBAL</td> <td>M0</td> </tr> </tbody> </table>			Label Name	Data Type	Class	Assign (Device/Label)	InterlockStart	Bit	VAR_GLOBAL	M0
Label Name	Data Type	Class	Assign (Device/Label)								
InterlockStart	Bit	VAR_GLOBAL	M0								

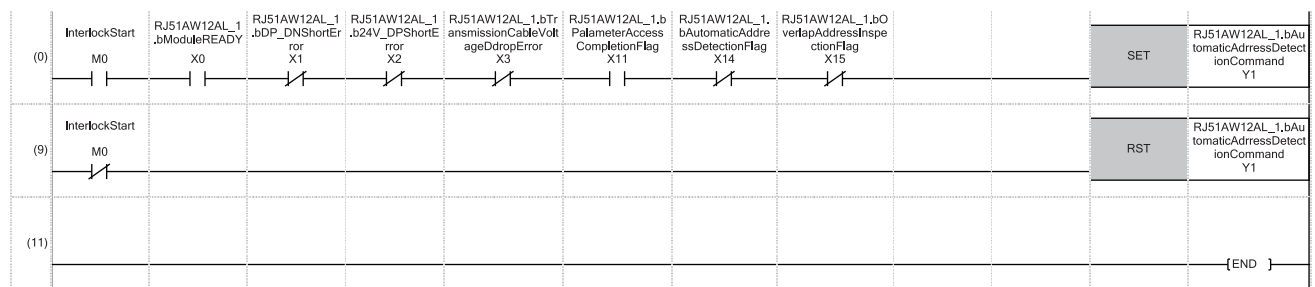

3.2 Communication Example When the Slave Module is Added or Deleted

The parameter of the slave module is moved over in order of ID and stored in 'Parameter storage area' (Un\G12288 to Un\G18431) after the automatic address detection function is executed.

Because of this, the address of the parameter storage area for the slave module later than the ID where the slave module is added or deleted in the AnyWireASLINK system is changed. (The parameter of a non-existing ID is deleted and displayed.) Therefore, the address of the slave module later than the ID where the slave module is added or deleted must be changed when a program is created with buffer memory addresses directly specified. (This also applies if the ID is changed and sorting order is switched.)

To create a program that reads/writes the parameter without considering the addition or deletion of slave modules, use the following buffer memory areas.

Address	Name
Un\G10496 to Un\G10751	Parameter storage location memory number (bit output)
Un\G11008 to Un\G11263	Parameter storage location memory number (bit input)
Un\G19456 to Un\G19967	Parameter storage location memory number (word output)
Un\G19968 to Un\G20479	Parameter storage location memory number (word input)

After automatic address detection, the start address of the buffer memory that stores the parameter of the ID is stored in these areas. (☞ Page 105 Parameter storage location memory number)

System configuration example

This section describes when the ASLINKER M12 connector type (input type) is added with address 10. A slave module (address 10) of (4) is added in the following system configuration.

System configuration

- Power supply module: R61P
- CPU module: R04CPU
- AnyWireASLINK master module: RJ51AW12AL (start I/O number: 0000H to 001FH)

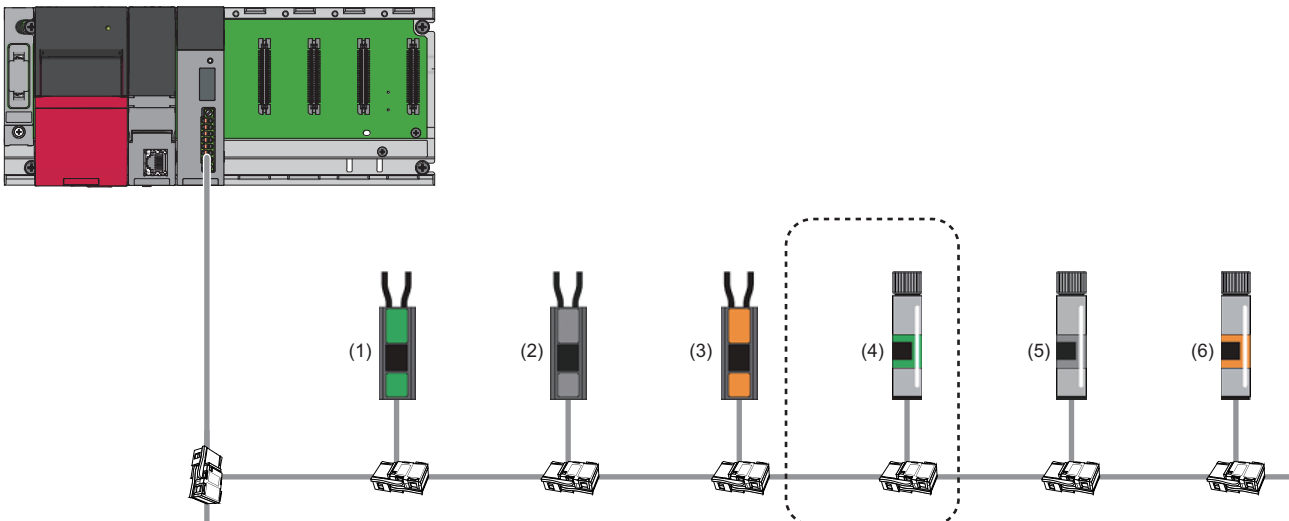

No.	Slave module		Address	ID
(1)	ASLINKER cable type	Input type	0	200H
(2)		Mixed type	2	202H
(3)		Output type	4	004H
(4)	ASLINKER M12 connector type	Input type	10	20AH
(5)		Mixed type	20	214H
(6)		Output type	22	016H

Buffer memory

■Change of 'Parameter storage area' (Un\G12288 to Un\G18431)

The parameter storage area of the ASLINKER M12 connector type (mixed type) with address 20 (ID: 214H) moves from the parameter storage area 5 to the parameter storage area 6, because the ASLINKER M12 connector type (input type) with address 10 (ID: 20AH) is added.

Buffer memory address	Parameter storage area	Before the slave module (address 10) is added	After the slave module (address 10) is added
Un\G12288 to Un\G12335	Parameter storage area 1	ASLINKER cable type (output type) parameter Address 4 (ID: 004H)	ASLINKER cable type (output type) parameter Address 4 (ID: 004H)
Un\G12336 to Un\G12383	Parameter storage area 2	ASLINKER M12 connector type (output type) parameter Address 22 (ID: 016H)	ASLINKER M12 connector type (output type) parameter Address 22 (ID: 016H)
Un\G12384 to Un\G12431	Parameter storage area 3	ASLINKER cable type (input type) parameter Address 0 (ID: 200H)	ASLINKER cable type (input type) parameter Address 0 (ID: 200H)
Un\G12432 to Un\G12479	Parameter storage area 4	ASLINKER cable type (mixed type) parameter Address 2 (ID: 202H)	ASLINKER cable type (mixed type) parameter Address 2 (ID: 202H)
Un\G12480 to Un\G12527	Parameter storage area 5	ASLINKER M12 connector type (mixed type) parameter Address 20 (ID: 214H)* ²	ASLINKER M12 connector type (input type) parameter Address 10 (ID: 20AH)* ¹
Un\G12528 to Un\G12575	Parameter storage area 6	No data	ASLINKER M12 connector type (mixed type) parameter Address 20 (ID: 214H)* ¹
⋮	⋮	⋮	⋮
Un\G18384 to Un\G18431	Parameter storage area 128	No data	No data

*1 The parameter of the slave module with address 10 (ID: 20AH), which has been added, is stored.

*2 The parameter moves from the parameter storage area 5 to the parameter storage area 6.

■ Values stored in 'Parameter storage location memory number (bit output)' (Un\G10496 to Un\G10751) and 'Parameter storage location memory number (bit input)' (Un\G11008 to Un\G11263)

After the ASLINKER M12 connector type (input type) with address 10 (ID: 20AH) is added and then automatic address detection is executed, the values stored in 'Parameter storage location memory number (bit output)' (Un\G10496 to Un\G10751) and 'Parameter storage location memory number (bit input)' (Un\G11008 to Un\G11263) change as follows.

Buffer memory address	Data	Details	Slave module
Un\G10496	0000H	Output slave module ID 000H buffer memory start address	—
Un\G10497	0000H	Output slave module ID 001H buffer memory start address	—
Un\G10498	0000H	Output slave module ID 002H buffer memory start address	—
Un\G10499	0000H	Output slave module ID 003H buffer memory start address	—
Un\G10500	3000H	Output slave module ID 004H buffer memory start address	ASLINKER cable type (output type) Address 4 (ID: 004H)
Un\G10501	0000H	Output slave module ID 005H buffer memory start address	—
⋮	⋮	⋮	—
Un\G10518	3030H	Output slave module ID 016H buffer memory start address	ASLINKER M12 connector type (output type) Address 22 (ID: 016H)
⋮	⋮	⋮	—
Un\G10751	0000H	Output slave module ID 0FFH buffer memory start address	—
Un\G11008	3060H	Input/mixed slave module ID 200H buffer memory start address	ASLINKER cable type (input type) Address 0 (ID: 200H)
Un\G11009	0000H	Input/mixed slave module ID 201H buffer memory start address	—
Un\G11010	3090H	Input/mixed slave module ID 202H buffer memory start address	ASLINKER cable type (mixed type) Address 2 (ID: 202H)
Un\G11011	0000H	Input/mixed slave module ID 203H buffer memory start address	—
⋮	⋮	⋮	—
Un\G11018	0000H (before addition) → 30C0H (after addition)	Input/mixed slave module ID 20AH buffer memory start address	ASLINKER M12 connector type (input type) Address 10 (ID: 20AH)
⋮	⋮	⋮	—
Un\G11028	30C0H (before addition) → 30F0H (after addition)	Input/mixed slave module ID 214H buffer memory start address	ASLINKER M12 connector type (mixed type) Address 20 (ID: 214H)
⋮	⋮	⋮	—
Un\G11263	0000H	Input/mixed slave module ID 2FFH buffer memory start address	—

Setting in the RJ51AW12AL

Connect an engineering tool to the CPU module and set parameters.

1. Set the CPU module as follows.

 [Project] ⇒ [New]

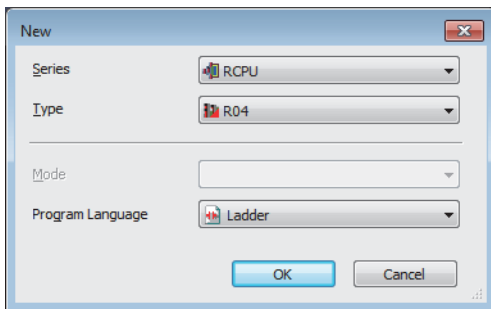

2. Click the [OK] button to add the module labels of the CPU module.

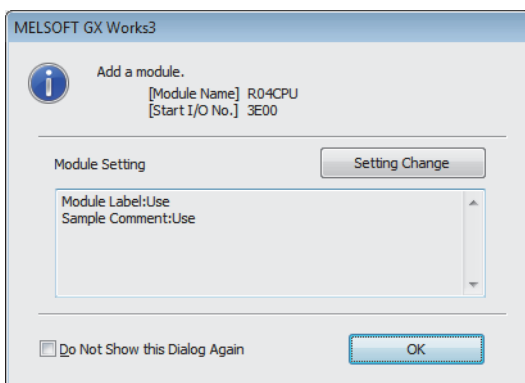

3. Set the RJ51AW12AL as follows.

 [Navigation window] ⇒ [Parameter] ⇒ [Module Information] ⇒ Right click ⇒ [Add New Module]

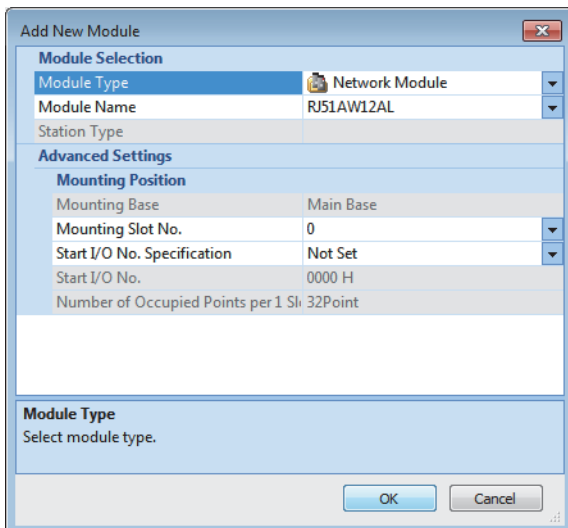

4. Click the [OK] button to add the module labels of the RJ51AW12AL.

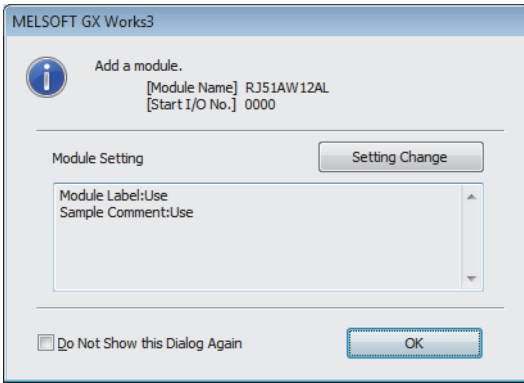

5. Set the items in "Basic setting" as follows.

[Navigation window] ⇒ [Parameter] ⇒ [Module Information] ⇒ [RJ51AW12AL] ⇒ [Module Parameter] ⇒ [Basic setting]

Item	Setting Value
Transmission points	
Transmission points setting	3: 512 points(256 input points/256 output points)
Startup operating mode	
Startup operating mode setting	0: Without slave information acquisition
Double verification	
Double verification setting	0: All points, double verification of a bit
Error status automatic recovery	
Error status automatic recovery mode setting	0: No error status automatic recovery
Output data hold/clear setting when error occurs	
Output data hold/clear setting when error occurs	0: CLEAR
Word input data hold/clear setting when error occurs	
Word input data hold/clear setting when error occurs	0: CLEAR
Easy replacement enable/disable setting for one slave mod	
Easy replacement enable/disable setting for one slave mod	0: Enable
Word data points setting	
To use or not to use word data setting	0: Not use
Word data points setting	0: word data (no word data)
Word data start address	0
Word data points setting per frame	0: word data (no word data)

6. Write the set parameters into the CPU module, and reset the CPU module or power off and on the system.

[Online] ⇒ [Write to PLC]

Point

In this example, default values were used for parameters that are not shown above. For the parameters, refer to the following.

☞ Page 48 PARAMETER SETTINGS

Settings in the slave modules

Write addresses to slave modules and register them with the RJ51AW12AL.

Address setting

Write addresses to slave modules with an address writer.

 Page 63 System configuration example

Automatic address detection

Keep pressing the SET switch on the RJ51AW12AL until the SET LED turns on.

When the SET LED flashes and then turns off, it indicates that the registration of IDs (addresses) has been completed.

Checking the system status

Check whether the RJ51AW12AL can communicate with the slave modules normally.

The following LED statuses indicate that the communication is established normally.

- LED of the RJ51AW12AL

LED	Status
RUN LED	On
ERR LED	Off
LINK LED	Flashing
SET LED	Off
ALM LED	Off

- LED of the ASLINKER

LED	Status
LINK LED	Flashing
ALM LED	Off

Program example

This section provides examples of programs that read the status details and sensing level information. Parameters of a threshold value can be written in the same way as parameter read.

Reading the status details (I/O disconnection)

The following shows a program example that reads the status details of the slave module (address: 20) when the start I/O number of the RJ51AW12AL is assigned to X/Y00 to X/Y1F.

Classification	Label name	Description	Device	
Module label	RJ51AW12AL_1.bModuleREADY	Module READY	X0	
	RJ51AW12AL_1.bDP_DNShortError	DP/DN short error	X1	
	RJ51AW12AL_1.b24V_DPShortError	24V/DP short error	X2	
	RJ51AW12AL_1.bTransmissionCableVoltageDdropError	Transmission cable voltage drop error	X3	
	RJ51AW12AL_1.bDP_DNDisconnectionError	DP/DN disconnection error	X4	
Label to be defined	Define global labels as shown below:			
	Label Name	Data Type	Class	Assign (Device/Label)
	TimerContact	Timer	VAR_GLOBAL	T0
	ProgramStart	Bit	VAR_GLOBAL	M1
	ParamAdd_214	Word [Signed]	VAR_GLOBAL	U0VG11028
	StatusArea_214	Word [Signed]	VAR_GLOBAL	D3000
	DisconnectionArea_214	Bit	VAR_GLOBAL	D3000.2
	Disconnection	Bit	VAR_GLOBAL	M2
	StatusError	Bit	VAR_GLOBAL	M3

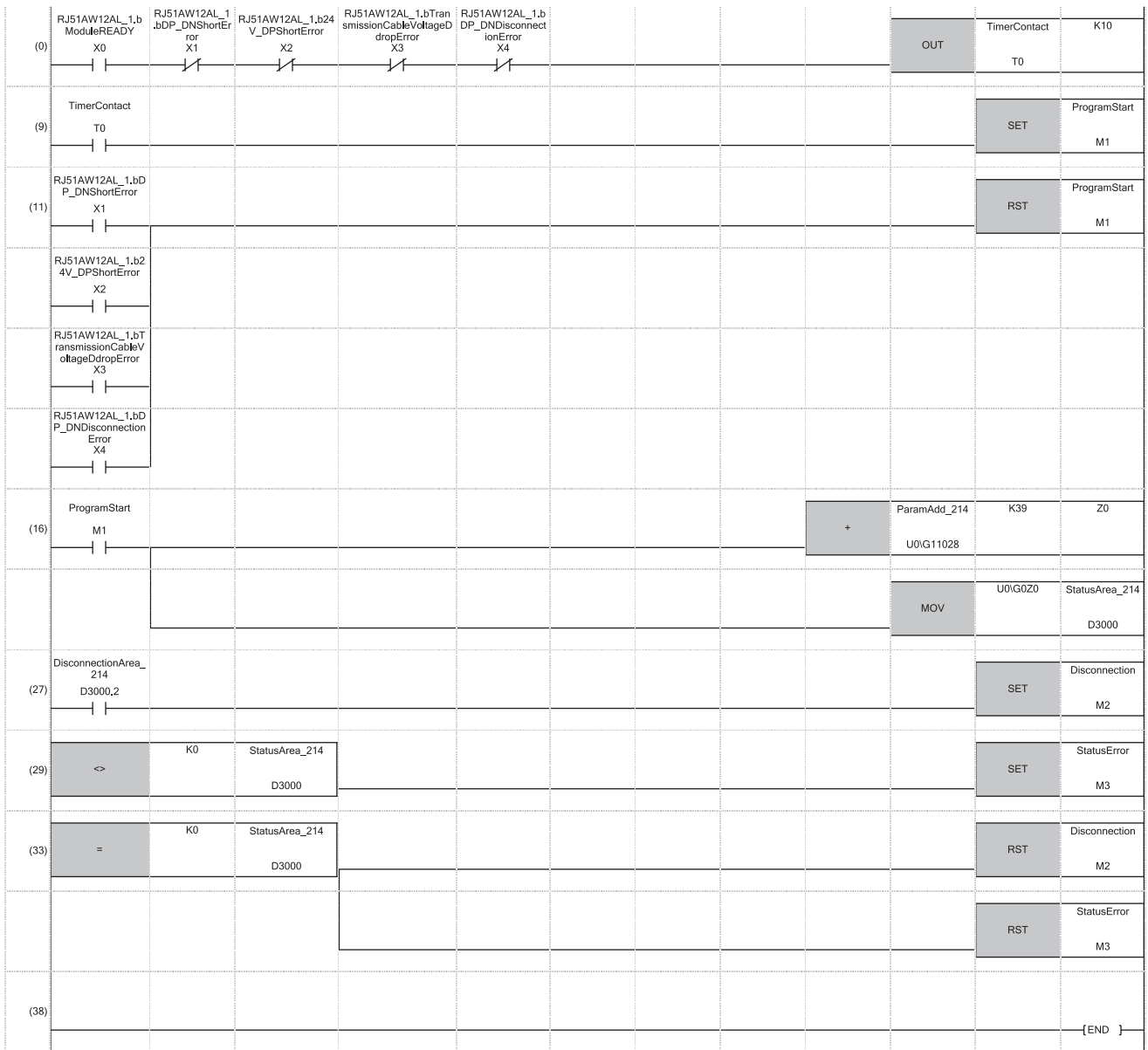

(16) Once 'ProgramStart' (M1) turns on, the buffer memory address determined by adding 39 to 'ParamAdd_214' (U0G11028) of the slave module (ID: 214H) with the address 20 is stored in 'StatusArea_214' (D3000).

(27) 'I/O disconnection detection flag' (M2) turns on when a disconnection of the slave module (ID: 214H) with the address 20 is detected.

(29) 'Status details error detection flag' (M3) turns on when an error of the slave module (ID: 214H) with the address 20 is detected.

The status details of the slave module (address 20) are stored in 40th (UnG12567) of 48 words of the parameter storage area 6 (UnG12528 to UnG12575). (☞ Page 109 Parameters)

Reading the sensing level information

The sensing level is a device parameter for the ASLINKAMP or ASLINKSENSOR only.

This example uses a system configuration in which an ASLINKAMP or ASLINKSENSOR is used as a slave module with address 20 instead of the ASLINKER M12 connector type (mixed type) in the system configuration above.

This section describes an example of a program in which the photoelectric transmission type ASLINKSENSOR is used.

The photoelectric transmission type operates based on the combination of the two types: "Transmission floodlight type" and "Transmission light receiving type".

If the slave module with address 20 is replaced with the ASLINKSENSOR, two slave modules, "Transmission floodlight type" and "Transmission light receiving type" (both have address 20.), will be added. Thus, the system is configured with seven slave modules.

The following shows a program example that reads the sensing level of the slave module (address: 20) when the start I/O number of the RJ51AW12AL is assigned to X/Y00 to X/Y1F.

Classification	Label name	Description	Device																				
Module label	RJ51AW12AL_1.bModuleREADY	Module READY	X0																				
	RJ51AW12AL_1.bDP_DNShortError	DP/DN short error	X1																				
	RJ51AW12AL_1.b24V_DPShortError	24V/DP short error	X2																				
	RJ51AW12AL_1.bTransmissionCableVoltageDdropError	Transmission cable voltage drop error	X3																				
	RJ51AW12AL_1.bDP_DNDisconnectionError	DP/DN disconnection error	X4																				
Label to be defined	Define global labels as shown below:																						
	<table border="1"> <thead> <tr> <th>Label Name</th> <th>Data Type</th> <th>Class</th> <th>Assign (Device/Label)</th> </tr> </thead> <tbody> <tr> <td>TimerContact</td> <td>Timer</td> <td>VAR_GLOBAL</td> <td>T0</td> </tr> <tr> <td>ProgramStart</td> <td>Bit</td> <td>VAR_GLOBAL</td> <td>M1</td> </tr> <tr> <td>ParamAdd_214</td> <td>Word [Signed]</td> <td>VAR_GLOBAL</td> <td>U0/G11028</td> </tr> <tr> <td>SensingLevelArea_214</td> <td>Word [Signed]</td> <td>VAR_GLOBAL</td> <td>D4000</td> </tr> </tbody> </table>	Label Name	Data Type	Class	Assign (Device/Label)	TimerContact	Timer	VAR_GLOBAL	T0	ProgramStart	Bit	VAR_GLOBAL	M1	ParamAdd_214	Word [Signed]	VAR_GLOBAL	U0/G11028	SensingLevelArea_214	Word [Signed]	VAR_GLOBAL	D4000		
Label Name	Data Type	Class	Assign (Device/Label)																				
TimerContact	Timer	VAR_GLOBAL	T0																				
ProgramStart	Bit	VAR_GLOBAL	M1																				
ParamAdd_214	Word [Signed]	VAR_GLOBAL	U0/G11028																				
SensingLevelArea_214	Word [Signed]	VAR_GLOBAL	D4000																				

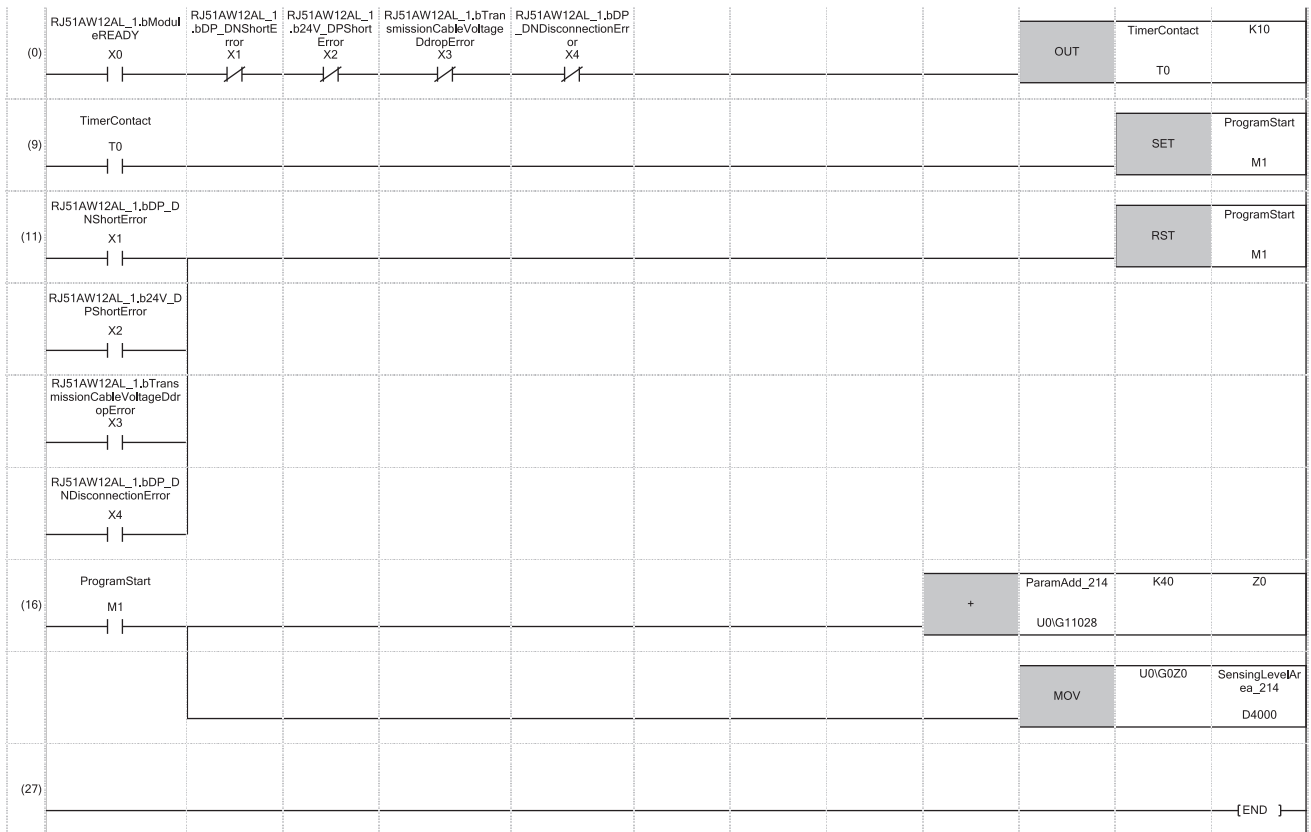

(16) Once 'ProgramStart' (M1) turns on, the buffer memory address determined by adding 40 to 'ParamAdd_214' (U0G11028) of the slave module (ID: 214H) with the address 20 is stored in 'SensingLevelArea_214' (D4000).

The sensing level of the slave module (address 20) is stored in 41st (UnG12616) of 48 words of the parameter storage area 7 (UnG12576 to UnG12623). (☞ Page 109 Parameters)

4 TROUBLESHOOTING

This chapter describes the troubleshooting of the RJ51AW12AL.

4.1 Checking with LED

This section describes troubleshooting using LED.

When the RUN LED turns off

When the RUN LED turns off after powering on the RJ51AW12AL, check the following.

Check item	Action
Is the RJ51AW12AL mounted correctly?	Securely mount the RJ51AW12AL on the base unit.

When the ERR LED turns on or flashes

When the ERR LED turns on or flashes, check the following.

Check item	Action
Does any error occur in the module diagnostics?	Take the actions displayed on the window.
Was the power turned off during automatic address detection?	Execute automatic address detection again. Executing automatic address detection will recover corrupted data in the EEPROM.
Is the word data points setting value within the setting range?	Set the number of word data points within the setting range.

When the LINK LED turns on or off

When the LINK LED turns on or off, check the following.

Check item	Action
Does a programmable controller error occur in the engineering tool?	Check the error with the engineering tool and correct the error.
Is the AnyWireASLINK version compatibility inspection in progress?	Wait for the AnyWireASLINK version compatibility inspection to complete.

When the ALM LED is flashing at 0.2 second intervals

When the ALM LED is flashing at 0.2 second intervals, check the following.

Check item	Action
Does a programmable controller error occur in the buffer memory?	Check the error with the buffer memory and correct the error. (Page 76 Checking with the buffer memory)
Is the power supply voltage of the 24VDC external power supply within the rated value?	Adjust the power supply voltage of the 24VDC external power supply within the rated value (21.6 to 27.6VDC). (The recommended voltage is 26.4VDC.)
Is any power cable short-circuited?	<ul style="list-style-type: none">• Check that the power cables (24V, 0V) are not disconnected or short-circuited.• When crimping the link connector, check that the pin layout is correct.
Is the terminal block properly wired?	<ul style="list-style-type: none">• Check that the 24VDC external power supply is properly connected to the terminal blocks of the RJ51AW12AL and the slave module.• Check that there is no short circuit or incorrect wiring and screws are tightened sufficiently.
Is the current consumption of the AnyWireASLINK system within the specified range?	Correct the cables (wire diameter, total wiring length) and modules (type, the number of connected modules) so that the current consumption of all the slave modules does not exceed the transmission cable supply current of the RJ51AW12AL. MELSEC iQ-R AnyWireASLINK Master Module User's Manual (Startup)

When the ALM LED is flashing at 1 second intervals

When the ALM LED is flashing at 1 second intervals, check the following.

Check item	Action
Does a programmable controller error occur in the buffer memory?	Check the error with the buffer memory and correct the error. (☞ Page 76 Checking with the buffer memory)
Is any transmission cable (between DP and DN, between 24V and DP, or between 0V and DP) short-circuited?	<ul style="list-style-type: none"> • Check that the transmission cables (between DP and DN, between 24V and DP, or between 0V and DP) are not short-circuited. • When crimping the link connector, check that the pin layout is correct.
Is the terminal block properly wired?	Check that the transmission cables (DP, DN) are not in contact with each other and that there is no incorrect wiring in the terminal block wiring of the RJ51AW12AL and the slave module.
Is the current consumption of the AnyWireASLINK system within the specified range?	Correct the cables (wire diameter, total wiring length) and modules (type, the number of connected modules) so that the current consumption of all the slave modules does not exceed the transmission cable supply current of the RJ51AW12AL. (☞ MELSEC iQ-R AnyWireASLINK Master Module User's Manual (Startup))

When the ALM LED is on

When the ALM LED is on, check the following.

Check item	Action
Does a programmable controller error occur in the buffer memory?	Check the error with the buffer memory and correct the error. (☞ Page 76 Checking with the buffer memory)
Is any transmission cable (DP, DN) disconnected?	<ul style="list-style-type: none"> • Check that the transmission cables (DP, DN) are free from disconnection. • Check that the cables are crimped with proper pin layout using link connectors appropriate to the wire diameter.
Is the terminal block properly wired?	<ul style="list-style-type: none"> • Check that the transmission cables (DP, DN) and power cables (24V, 0V) are properly connected to the terminal block of the RJ51AW12AL. • Check that there is no incorrect wiring and that screws are tightened sufficiently.
Has the automatic address detection been executed?	When creating a new system, adding or removing a slave module, or changing the address of the slave module, execute the automatic address detection. (☞ Page 58 Automatic Address Detection Function) After executing the automatic address detection function, check that the number of slave modules and the address are consistent with those of the actual system.
Is the slave module operating properly?	When the LINK LED of the slave module does not flash, check that there is no disconnection, short circuit, incorrect wiring, or poor contact in the transmission cables (DP, DN) around the module.
Does an AnyWireASLINK version compatibility inspection error exist?	For measures to be taken, refer to the following. ☞ Page 79 When the AnyWireASLINK version compatibility inspection cannot be executed
Does a Backup/Restore unsupported error exist?	For measures to be taken, refer to the following. ☞ Page 79 When the backup/restoring function is not available

When the SET LED turns on and does not turn off

When the SET LED turns on and does not turn off, check the following.

Check item	Action
Was the power turned off during automatic address detection?	Execute automatic address detection again. Executing automatic address detection will recover corrupted data in the EEPROM.

4.2 Checking Module Status

Checking with the "Module Diagnostics" window

The following items can be checked in the "Module Diagnostics" window of the RJ51AW12AL.

Item	Description
Error Information	Displays the details of the errors currently occurring. Clicking the [Event History] button will display the history of errors that occurred in AnyWireASLINK and errors that occurred and operations that were performed in modules.
Module Information List	This item does not support the RJ51AW12AL.

Error Information

Check the details of errors that have occurred and actions for the errors.

Module Diagnostics(Start I/O No. 0000)

Module Name: RJ51AW12AL, Production information: 0101351300000000

Supplementary Function: [Dropdown], Execute, Stop Monitoring

Monitoring: [Green Button], Stop Monitoring

No.	Occurrence Date	Status	Error Code	Overview
1	2016/05/09 14:14:50.397	Major	3068	CPU module stop error(IORSTL signal detected)

Buttons: Error Jump, Event History, Clear Error, Detail

Legend: Major (Red Triangle), Moderate (Yellow Triangle), Minor (Green Triangle)

Detailed Information	-	-	-
Cause	A stop error has occurred in the CPU module.		
Corrective Action	Check and correct the error using the PLC diagnostics of the programming tool.		

Buttons: Create File..., Close

Item	Description
Detailed Information	Displays detailed information about each error (maximum of 3 pieces).
Cause	Displays the detailed error causes.
Corrective Action	Displays the actions to eliminate the error causes.

Checking with the buffer memory

The following shows the check method with the buffer memory.

Check method

[Online] ⇒ [Monitor] ⇒ [Device/Buffer Memory Batch Monitor]

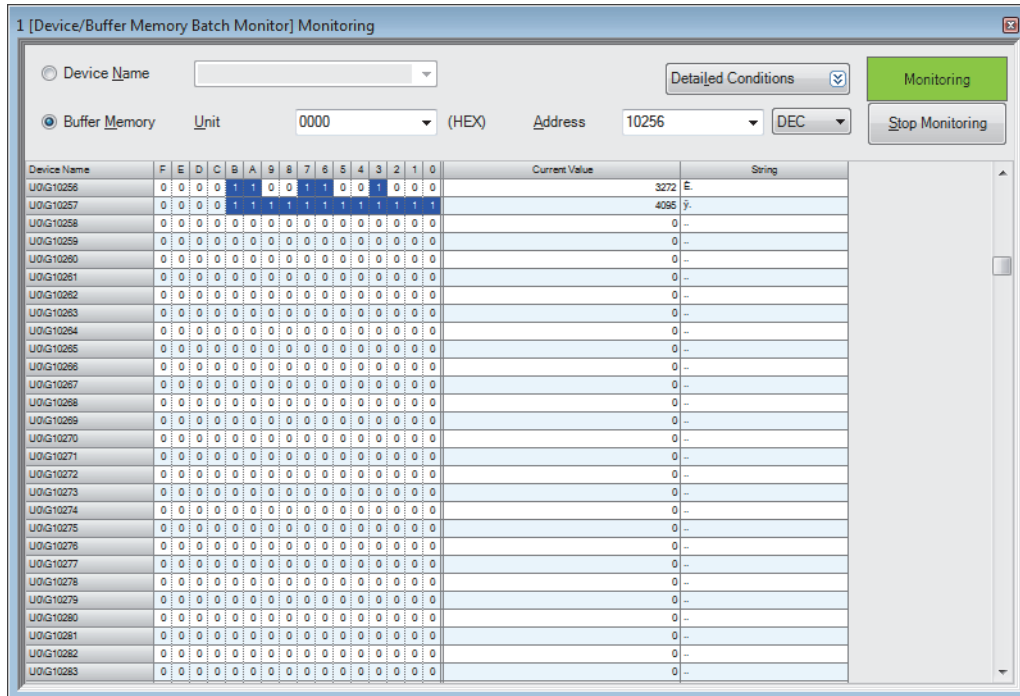

Check item

For details on the buffer memory, refer to the following.

☞ Page 94 Buffer Memory

■Check of the error details

The error code of the RJ51AW12AL is stored in 'Latest error code storage area' (Un\G10256).

■Check of the error ID area

The number of error IDs is stored in 'Number of the error IDs' (Un\G8192) and the ID information is stored in 'Error ID information storage area' (Un\G8193 to Un\G8320).

■Check of the alarm signal area

The number of slave modules having an error is stored in 'Number of the alarm IDs' (Un\G9984) and the ID information is stored in 'Alarm ID information storage area' (Un\G9985 to Un\G10112).

■Check of the error details of the slave module

The details of errors in the slave module are stored in the status details in 'Parameter storage area' (Un\G12288 to Un\G12335).* 1

*1 Buffer memory addresses when one slave module is connected. For details, refer to the following.

☞ Page 107 Parameter storage area

4.3 Troubleshooting by Symptom

This section describes troubleshooting method by symptom. If an error has occurred in the RJ51AW12AL, identify the error cause with an engineering tool. (🔧 Page 75 Checking Module Status)

AnyWireASLINK transmission is not available

When AnyWireASLINK transmission is not available, check the following.

Check item	Action
Is the LINK LED of the RJ51AW12AL on or off?	Perform the troubleshooting for when the LINK LED is on or off. (🔧 Page 73 When the LINK LED turns on or off)
Are the number of transmission points of the RJ51AW12AL and the address setting of the slave module correct?	<ul style="list-style-type: none"> • Check that the address of the slave module is within the number of transmission points of the RJ51AW12AL. • Check that the ID or occupied address range of the slave module is not the same as that of other slave modules. • When using word transmission, check that the setting items are correct. • Check that the bit address is not mixed up with the word address.
Does the total wiring length of the transmission cables (DP, DN) exceed 200m?	Adjust the total wiring length within 200m.
Do the wires or cables used satisfy standards?	When they do not satisfy the standards, change the wires or cables with the ones that satisfy the standards.

When communication is unstable

When communications are unstable, check the following.

Check item	Action
Is the ambient temperature for the module within the specified range?	Keep the ambient temperature within the specified range by taking action such as removing heat source.
Is there any noise affecting the system?	Check the wiring condition.
Is the terminating unit connected properly?	Pay attention to the polarities of the terminating unit and connect it properly.
Does the total wiring length of the transmission cables (DP, DN) exceed the specified range?	Adjust the total wiring length of the AnyWireASLINK system within the specified range.
Do the transmission cables (DP, DN) satisfy the specifications?	<ul style="list-style-type: none"> • Use transmission cables (DP, DN) that satisfy the specifications such as the type and wire diameter, and tightening torque to the terminal block. • Do not run multiple transmission cables (DP, DN) using a multicore cable.
Does the power supply voltage of the 24VDC external power supply satisfy the specifications?	Adjust the power supply voltage of the 24VDC external power supply within the rated value (21.6 to 27.6VDC). (The recommended voltage is 26.4VDC.)
Are two or more RJ51AW12AL modules connected within one AnyWireASLINK line?	Connect only one RJ51AW12AL module within one AnyWireASLINK line.
Are there AnyWireASLINK master modules of different series connected within one AnyWireASLINK line?	Connect only one AnyWireASLINK master module within one AnyWireASLINK line.
Are the RJ51AW12AL module and AnyWireASLINK bridge module connected within one AnyWireASLINK line?	Connect only one RJ51AW12AL module or AnyWireASLINK bridge module within one AnyWireASLINK line.

When data of the slave module cannot be checked

When I/O data and parameter data of the slave module cannot be checked, check the following.

Check item	Action
Is the I/O information of the slave module stored in the following buffer memory addresses in the program? <ul style="list-style-type: none"> • 'Bit input information area' (Un\G0 to Un\G15) • 'Word input information area' (Un\G512 to Un\G1023) • 'Bit output information area' (Un\G4096 to Un\G4111) • 'Word output information area' (Un\G4608 to Un\G5119) 	Check that information regarding the slave module has been properly assigned and that the commands written in the program are free from mistakes.
Are the I/O LEDs of the slave module normal?	Check the I/O LED status of the slave module and check that there is no disconnection, short circuit, or poor contact in the wiring on the load side.
Are two or more RJ51AW12AL modules connected within one AnyWireASLINK line?	Connect only one RJ51AW12AL module within one AnyWireASLINK line.
Are the number of transmission points of the RJ51AW12AL and the address setting of the slave module correct?	<ul style="list-style-type: none"> • Check that the address of the slave module is within the setting range of the number of points of the RJ51AW12AL. • Check that the ID or occupied address range of the slave module is not the same as that of other slave modules. • When using word transmission, check that the setting items are correct. • Check that the bit address is not mixed up with the word address.
Are the automatic address detection and AnyWireASLINK version compatibility inspection in progress?	Check again after the automatic address detection and AnyWireASLINK version compatibility inspection complete.

When the easy replacement setting for one slave module is not available

When the easy replacement setting for one slave module is not available, check the following.

Check item	Action
Is the easy replacement setting for one slave module enabled?	Enable the easy replacement setting for one slave module by setting the module parameter. (☞ Page 51 Enabling/disabling the easy replacement setting for one slave module)
Does a DP/DN disconnection error exist on only one slave module?	Disconnect the slave module to be replaced from the transmission cable, and replace it using the easy replacement for one slave module function. To replace two or more slave modules, turn off the power after replacing the first module, disconnect the second slave module, and replace it using the easy replacement setting for one slave module.
Are the old and new slave modules of the same type?	Replace the slave module with a new one of the same type.
Was the slave module replaced with a new one of an updated device version?	Replace the slave module with a new one of an updated device version.
Is the new slave module connected firmly?	Connect the new slave module firmly to the transmission cable.
Does the new slave module support easy replacement function for one slave module?	Replace the slave module with a new one supporting easy replacement function for one slave module.
Do any errors other than DP/DN disconnection errors exist?	Eliminate errors other than DP/DN disconnection errors, and replace the slave module using the easy replacement for one slave module function.

When the AnyWireASLINK version compatibility inspection cannot be executed

When the AnyWireASLINK version compatibility inspection cannot be executed, check the following.

Check item	Action
Is the word data points setting of the RJ51AW12AL valid?	Set the word data points setting of the RJ51AW12AL to 2 words (1 input word/ 1 output word) or larger, and execute the AnyWireASLINK version compatibility inspection.
Is an error code other than an AnyWireASLINK version compatibility inspection error stored in the latest error code storage area?	Eliminate errors other than an AnyWireASLINK version compatibility inspection error, and execute the AnyWireASLINK version compatibility inspection.
Is a slave module with a duplicate ID connected?	Change the address of the slave module so that the ID is not duplicated, and execute the AnyWireASLINK version compatibility inspection.
Is a connected slave module broken?	Replace the broken slave module, and execute the AnyWireASLINK version compatibility inspection.
Are slave modules more than the maximum number of connectable modules connected?	Reduce the number of connected slave modules to the maximum number of connectable modules or less, and execute the AnyWireASLINK version compatibility inspection.

When the backup/restoring function is not available

When the backup/restoring function is not available, check the following.

Check item	Action
Is the CPU module in use support backup/restoration?	Use a CPU module that supports backup/restoration. For the versions of CPU modules supporting backup/restoration, refer to the following.  iQ Sensor Solution Reference Manual

4.4 List of Error Codes

This section describes errors that occur in processing for data communication between the RJ51AW12AL and slave modules and in processing requests from the CPU module, and error codes, error definitions, and causes of the errors, and actions against the errors.

Error code	Error details and causes	Action	Detailed information
0CC8H	Transmission cable voltage drop error	<p>The voltage of the 24VDC external power supply may be insufficient. Perform the following:</p> <ul style="list-style-type: none"> Adjust the power supply voltage of the 24VDC external power supply within the rated value (21.6 to 27.6VDC). (The recommended voltage is 26.4VDC.) Check that the power cables (24V, 0V) are not disconnected or short-circuited. When crimping the link connector, check that the pin layout is correct. Check that the 24VDC external power supply is properly connected to the terminal blocks of the RJ51AW12AL and the slave module. Check that there is no short circuit or incorrect wiring and screws are tightened sufficiently. 	—
0CC9H	DP/DN short error	<p>A short-circuit may be occurring in the transmission cables (DP, DN) or the maximum supply current of the transmission cables (DP, DN) may be exceeded. Perform the following:</p> <ul style="list-style-type: none"> Check that the transmission cables (DP, DN) are not short-circuited. When crimping the link connector, check that the pin layout is correct. Check that the transmission cables (DP, DN) are not in contact with each other and that there is no incorrect wiring in the terminal block wiring of the RJ51AW12AL and the slave module. Correct the cables (wire diameter, total wiring length) and modules (type, the number of connected modules) so that the current consumption of all the slave modules does not exceed the transmission cable supply current of the RJ51AW12AL. 	—
0CCA H	DP/DN disconnection error	<p>The transmission cables (DP, DN) may be disconnected, or there may be no response from the slave module. The slave module may be in failure or the system configuration may have been changed after the automatic address detection. Check 'Number of the error IDs' (Un\G8192) and 'Error ID information storage area' (Un\G8193 to Un\G8320), find out the disconnected area, and perform the following:</p> <ul style="list-style-type: none"> Check that the transmission cables are free from disconnection. Check that the cables are crimped with proper pin layout using link connectors appropriate to the wire diameter. Check that the transmission cables (DP, DN) are properly connected to the terminal block of the RJ51AW12AL. Check that there is no incorrect wiring and that screws are tightened sufficiently. When creating a new system, adding or removing a slave module, or changing the address of the slave module, execute the automatic address detection. After executing the automatic address detection function, check that the number of slave modules and the address are consistent with those of the actual system. If the LINK LED of the slave module does not flash, check that there is no disconnection, short circuit, incorrect wiring, or poor contact in the transmission cables (DP, DN) around the module. 	—
0CCBH	24V/DP short error	<p>A short-circuit may be occurring in the transmission cables (24V, DP). Perform the following:</p> <ul style="list-style-type: none"> Check that the transmission cables (24V, DP) are not short-circuited. When crimping the link connector, check that the pin layout is correct. Check that the transmission cables (24V, DP) are not in contact with each other and that there is no incorrect wiring in the terminal block wiring of the RJ51AW12AL and the slave module. 	—

Error code	Error details and causes	Action	Detailed information
0D2CH	Slave module hardware error	Writing data to read only areas in the slave module was attempted. Perform either of the following operations. • Reset the CPU module or power off and on the system. • Power off and on the slave module. Check that there is no influence from noise. When the error occurs during easy replacement for one slave module or remote address change, check that the slave module supports those functions.	—
0D2DH	Slave module hardware error	Reading data from write only areas in the slave module was attempted. Perform either of the following operations. • Reset the CPU module or power off and on the system. • Power off and on the slave module. Check that there is no influence from noise.	—
0D2EH	Parameter access target module ID error	The RJ51AW12AL accessed the parameter of the ID where the automatic address detection has not been executed. Check that the slave module ID for parameter access in the actual system matches that of the program. • Bit input slave module ID (address + 200H) • Bit I/O combined slave module ID (address + 200H) • Word output slave module ID (address + 400H) • Word input slave module ID (address + 600H) • Word I/O combined slave module ID (address + 600H) When creating a new system, adding or removing a slave module, or changing the address of the slave module, execute the automatic address detection. After executing the automatic address detection function, check that the number of slave modules and the address are consistent with those of the actual system. Check that one or more slave modules have been registered.	—
0D2FH	Parameter value error	The slave module has detected a signal of writing a parameter that cannot be set to the slave module itself. Check 'Number of the alarm IDs' (Un\G9984) and 'Alarm ID information storage area' (Un\G9985 to Un\G10112) to find out the error ID. Then check that the slave module parameter setting value is within the allowable setting range.	—
0D30H	Parameter access error	The parameter access signal sent by the RJ51AW12AL is corrupt. Check that none of the following errors have occurred. (☞ Page 29 How to check the parameter access error status) • Slave module hardware error • Slave module status error • Same ID used error When none of the above have occurred, check that there is no influence from noise.	—
0D31H	Slave module status error	The slave module has notified of error status. Check the target module's status details and solve the problem.	—
0D80H	Type mismatch error	When a slave module is replaced using the easy replacement function for one slave module, the type of the new slave module is different from that of the old slave module. Connect a proper slave module.	—
0D81H	Replacement error due to use of slave module of earlier device version	Replacement by the easy one-device replacement function has failed because the old slave module was replaced with a new slave module of an earlier device version than the one of the old slave module. For easy one-device replacement, replace the old slave module with a new slave module of the same or a later device version than the one of the old slave module.	—
0D83H	Non-compatible slave module connection error detected in compatibility inspection	During the AnyWireASLINK version compatibility inspection, a non-compatible slave module was detected. Refer to the manual of the slave module having the ID detected in 'Sub information area' (Un\G12097 to Un\G12224).	—

Error code	Error details and causes	Action	Detailed information
0D84H	Access error detected in compatibility inspection	During the AnyWireASLINK version compatibility inspection, the access to the slave module failed, and the AnyWireASLINK version compatibility inspection was interrupted. Check the following on the slave module having the ID detected in 'Sub information area' (Un\G12097 to Un\G12224). <ul style="list-style-type: none"> • Check the slave module for disconnection, short circuit, incorrect wiring, and contact failure. • Check that the slave module ID is not duplicated. • Check that there is no influence from noise. 	—
0D85H	Excessive number of connected slave modules error detected in compatibility inspection	During the AnyWireASLINK version compatibility inspection, responses from slave modules more than the maximum number of connectable modules were detected, and the AnyWireASLINK version compatibility inspection was interrupted. Check the number of connected slave modules, and disconnect unnecessary slave modules. Check that the IDs of unnecessary slave modules are not connected to 'Sub information area' (Un\G12097 to Un\G12224).	—
0D90H	Same ID used error	The same ID (address) has been set to some of the connected slave modules. Check 'Number of the alarm IDs' (Un\G9984) and 'Alarm ID information storage area' (Un\G9985 to Un\G10112) to find out the error ID. Check the ID (address) of the slave module, and then set a unique number.	—
0D91H	No ID setting error	There is a slave module with no address setting. Perform the following: <ul style="list-style-type: none"> • Set the address of the bit slave module to a value other than 255 and 511. • Set the address of the word slave module to a value other than 511. 	—
0D92H	New ID error	The new ID (address) of the slave module may be in the following condition. <ul style="list-style-type: none"> • The ID has already been used. • The ID exceeds the allowable specification range. Check 'Connected module ID information storage area' (Un\G9217 to Un\G9344) and set another new ID (address).	—
0DF4H	Backup data error	The data backed up in the SD memory card of the CPU module is broken. Check that there is no influence from noise, and perform the following: <ul style="list-style-type: none"> • Reset the CPU module or power off and on the system, and then set the switch to RUN status again. • Use normal backup data, and restore the data. • Set the write protect switch of the SD memory card to off (writable). If the error occurs again, the SD memory card may be in failure. Please consult your local Mitsubishi representative.	—
0DF6H	Backup/Restore acceptance error (adjustment mode)	Backup or restoration was executed during the adjustment mode. Perform the following to execute backup. <ul style="list-style-type: none"> • Clear the error status by turning off and on 'Error flag clear command' (Y0), resetting the CPU module, or turning off and on the power. • Clear the adjustment mode execution status. 	—
0E05H	Backup/Restore unsupported error (word slave module ID)	Backup or restoration was executed using a CPU module not supporting word slave modules. Use a CPU module that supports word slave modules.	—
1867H	EEPROM access error	A malfunction has been detected in the RJ51AW12AL hardware. Reset the CPU module or power off and on the system. If the error occurs again, the RJ51AW12AL may be in failure. Please consult your local Mitsubishi representative.	—
186EH	EEPROM error (ID, parameter information)	An EEPROM error has been detected on the RJ51AW12AL. Power off and on the system after performing the automatic address detection function. If the error occurs again, the RJ51AW12AL may be in failure. Please consult your local Mitsubishi representative.	—

Error code	Error details and causes	Action	Detailed information
3064H to 3066H	RJ51AW12AL hardware failure	A malfunction has been detected in the RJ51AW12AL hardware. Reset the CPU module or power off and on the system. If the error occurs again, the RJ51AW12AL may be in failure. Please consult your local Mitsubishi representative.	—
3068H	CPU module stop error (IORSTL signal detection)	A stop error has occurred in the CPU module. Check the error in the "Module Diagnostics" window of an engineering tool and correct the error.	—
3069H	System error (NMI signal detection)	An internal control power supply error or watchdog timer error has occurred. Check the error in the "Module Diagnostics" window of an engineering tool and correct the error.	—
306BH	CPU module error (ITERR signal detection)	The RJ51AW12AL cannot receive signals from the CPU module. Check the error in the "Module Diagnostics" window of an engineering tool and correct the error.	—
306CH	ASIC access error (library I/F function access error)	A malfunction (ASIC access error) has been detected in the RJ51AW12AL hardware. Reset the CPU module or power off and on the system. If the error occurs again, the RJ51AW12AL may be in failure. Please consult your local Mitsubishi representative.	—

4.5 Event List

This section lists the events which occur in the RJ51AW12AL.

The events are classified into three types: system, error, and operation.

System		
Event code	Overview	Cause
00CC8	Transmission cable voltage drop error	The voltage of the 24VDC external power supply may be insufficient.
00CC9	DP/DN short error	A short-circuit may be occurring in the transmission cables (DP, DN) or the maximum supply current of the transmission cable (DP, DN) may be exceeded.
00CCA	DP/DN disconnection error	The transmission cable (DP, DN) may be disconnected, or there may be no response from the slave module.
00CCB	24V/DP short error	A short-circuit may be occurring in the transmission cables (24V, DP).
00D2C	Slave module hardware error (write to read only)	Writing data to read only areas in the slave module was attempted.
00D2D	Slave module hardware error (read from write only)	Reading data from write only areas in the slave module was attempted.
00D2E	Parameter access target module ID error	The parameter access is executed to the ID not detected by the automatic address detection.
00D2F	Parameter value error	The slave module has detected a signal of writing a parameter that cannot be set to the slave module itself.
00D30	Parameter access error	The sent parameter access signal is corrupt.
00D31	Slave module status error	The slave module is in the error state.
00D80	Type mismatch error	When a slave module is replaced using the easy replacement function for one slave module, the type of the new slave module is different from that of the old slave module.
00D81	Replacement error due to use of slave module of earlier device version	Replacement by the easy one-device replacement function has failed because the old slave module was replaced with a new slave module of an earlier device version than the one of the old slave module.
00D83	Non-compatible slave module connection error detected in compatibility inspection	During the AnyWireASLINK version compatibility inspection, a non-compatible slave module was detected.
00D84	Access error detected in compatibility inspection	During the AnyWireASLINK version compatibility inspection, the access to the slave module failed, and the AnyWireASLINK version compatibility inspection was interrupted.
00D85	Excessive number of connected slave modules error detected in compatibility inspection	During the AnyWireASLINK version compatibility inspection, responses from slave modules more than the maximum number of connectable modules were detected.
00D90	Same ID used error	The same ID (address) has been set to some of the connected slave modules.
00D91	No ID setting error	There is a slave module with no address setting.
00D92	New ID error	The new ID (address) of the slave module may be in the following condition. <ul style="list-style-type: none"> • The ID has already been used. • The ID exceeds the allowable specification range.
00DF4	Backup data error	The data backed up in the SD memory card of the CPU module is broken.
00DF6	Backup/Restore acceptance error (adjustment mode)	Backup or restoration was executed during the adjustment mode.
00E05	Backup/Restore unsupported error (word slave module ID)	Backup or restoration was executed using a CPU module not supporting word slave modules.
01867	EEPROM access error	A malfunction has been detected in the RJ51AW12AL hardware.
0186E	EEPROM error (ID, parameter information)	An EEPROM error has been detected on the RJ51AW12AL.
03064	RJ51AW12AL hardware failure (internal ROM error)	A malfunction has been detected in the RJ51AW12AL hardware.
03065	RJ51AW12AL hardware failure (internal RAM error)	A malfunction has been detected in the RJ51AW12AL hardware.
03066	RJ51AW12AL hardware failure (module initialization error)	A malfunction has been detected in the RJ51AW12AL hardware.
03068	CPU module stop error (IORITY signal detection)	A stop error has occurred in the CPU module.
03069	System error (NMI signal detection)	An error of the power supply or watchdog timer controlled internally has occurred.
0306B	CPU module error (ITERR signal detection)	The RJ51AW12AL cannot receive signals from the CPU module.
0306C	ASIC access error (library I/F function access error)	A malfunction (ASIC access error) has been detected in the RJ51AW12AL hardware.

Operation

Event code	Overview	Cause
24000	Error flag clear command	Error flag clear command was turned off and on.
24001	Automatic address detection command	Automatic address detection command was turned off and on.
24002	Overlap address inspection command	Overlap address inspection command was turned off and on.
24010	Parameter access request command for the slave module	Parameter access request command for the slave module was turned off and on.
24011	Parameter batch read command for the slave module	Parameter batch read command for the slave module was turned off and on.
24012	Parameter batch write command for the slave module	Parameter batch write command for the slave module was turned off and on.

APPENDICES

Appendix 1 Module Label

The I/O signals and buffer memory of the RJ51AW12AL can be set using module label.

Structure of the module label

The module label name is defined with the following structure.

"Instance name"_"Module number"."Label name"

"Instance name"_"Module number"."Label name"_D

Ex.

RJ51AW12AL_1.bModuleREADY

■Instance name

The following is the instance name of the RJ51AW12AL.

Model	Instance name
RJ51AW12AL	RJ51AW12AL

■Module number

A sequential number starting with "1" for identifying a module from the one with the same instance name.

■Label name

A label name unique to the module.

■_D

This symbol indicates that the module label is for direct access. The label without "_D" is for refresh. The following are the differences between refresh and direct access.

Type	Description	Access timing
Refresh	The values read/written from/to the module labels are reflected to the module at refresh. The execution time of the program can be shortened.	At refresh
Direct access	The values read/written from/to the module labels are reflected to the module immediately. Although the execution time of the program is longer than the one at the refresh, the responsiveness is improved.	At writing to or reading from the module label

Appendix 2 I/O Signals

This section describes the I/O signals for the CPU module. The assignment of the I/O signals when the start I/O number of the RJ51AW12AL is 0 is shown.

List of I/O signals

The following table lists I/O signals. Device X is an input signal from the RJ51AW12AL to the CPU module. Device Y is an output signal from CPU module to the RJ51AW12AL.

Input signal	
Device No.	Signal name
X0	Module READY
X1	DP/DN short error
X2	24V/DP short error
X3	Transmission cable voltage drop error
X4	DP/DN disconnection error
X5 to X7	Use prohibited
X8	AnyWireASLINK version compatibility inspection error ^{*1}
X9	Backup/Restore unsupported error ^{*1}
XA	Parameter access flag (with handshake) ^{*1}
XB	Parameter accessing flag (with handshake) ^{*1}
XC	Use prohibited
XD	AnyWireASLINK version compatibility inspection executing flag ^{*1}
XE	Use prohibited
XF	Adjustment mode executing flag ^{*1}
X10	Slave module alarm signal
X11	Parameter access completion flag
X12	Parameter access error
X13	Use prohibited
X14	Automatic address detection flag
X15	Overlap address inspection flag
X16	One slave module changing flag ^{*1}
X17	Slave module replacement completion flag ^{*1}
X18 to X1F	Use prohibited

*1 This signal is usable on the RJ51AW12AL of which first two digits of the production information are "03" or later.

Output signal

Device No.	Signal name
Y0	Error flag clear command
Y1	Automatic address detection command
Y2	Overlap address inspection command
Y3 to YC	Use prohibited
YD	AnyWireASLINK version compatibility inspection command ^{*1}
YE to YF	Use prohibited
Y10	Parameter access request command for the slave module
Y11	Parameter batch read command for the slave module
Y12	Parameter batch write command for the slave module
Y13 to Y1F	Use prohibited

*1 This signal is usable on the RJ51AW12AL of which first two digits of the production information are "03" or later.

Point

Do not use (turn on) any "use prohibited" signals as an input or output signal to the CPU module. Doing so may cause malfunction of the programmable controller system.

Details of the input signal

The following shows the on/off timing or condition of the input signal.

Module READY: X0

When the CPU module is reset or powered on, this signal turns on as soon as the RJ51AW12AL is completely ready to be processed.

DP/DN short error: X1

This signal turns on when a short circuit occurs in the transmission cables (DP, DN) or the maximum supply current is exceeded.

■Turning off of 'DP/DN short error' (X1)

After removing the short circuit in the transmission cables (DP, DN) or adjusting the current within the specification range, perform either of the following operations. Until then, 'DP/DN short error' (X1) remains on.

- Reset the CPU module or power off and on the system.
- Turn on and off 'Error flag clear command' (Y0).

For how to remove the short circuit in the transmission cables (DP, DN) or adjust the current within the specification range, refer to the following.

☞ Page 80 List of Error Codes

24V/DP short error: X2

This signal turns on when any of the transmission cables (24V, DP) is short-circuited.

■Turning off of '24V/DP short error' (X2)

After removing the short circuit in the transmission cables (24V, DP), perform either of the following operations. Until then, '24V/DP short error' (X2) remains on.

- Reset the CPU module or turn off and on the power.
- Turn on and off 'Error flag clear command' (Y0).

For how to remove the short circuit in the transmission cables (24V, DP), refer to the following.

☞ Page 80 List of Error Codes

Transmission cable voltage drop error: X3

This signal turns on when the 24VDC external power supply voltage drops.

■Turning off of 'Transmission cable voltage drop error' (X3)

After removing the drop of the 24VDC external power supply voltage, perform either of the following operations. Until then, 'Transmission cable voltage drop error' (X3) remains on.

- Reset the CPU module or power off and on the system.
- Turn on and off 'Error flag clear command' (Y0).

For how to remove the drop of the 24VDC external power supply voltage, refer to the following.

☞ Page 80 List of Error Codes

DP/DN disconnection error: X4

This signal turns on when the transmission cables (DP, DN) or a slave module is disconnected.

■Turning off of 'DP/DN disconnection error' (X4)

After removing the short circuit in the transmission cables (DP, DN) or reconnecting the slave module, perform either of the following operations. Until then, 'DP/DN disconnection error' (X4) remains on.*¹

- Reset the CPU module or power off and on the system.
- Turn on and off 'Error flag clear command' (Y0).

For how to remove the short circuit in the transmission cables (DP, DN) or reconnect the slave module, refer to the following.

☞ Page 80 List of Error Codes

*1 If the error status automatic recovery function is enabled, this signal turns automatically off.

AnyWireASLINK version compatibility inspection error: X8

This signal turns on when an error is detected in the AnyWireASLINK version compatibility inspection.

■Turning off of 'AnyWireASLINK version compatibility inspection error' (X8)

After the error is cleared, execute any of the following operations. Until then, 'AnyWireASLINK version compatibility inspection error' (X8) remains on.

- Reset the CPU module or power off and on the system.
- Turn on and off 'Error flag clear command' (Y0).
- Turn off and on 'AnyWireASLINK version compatibility inspection command' (YD).

Backup/Restore unsupported error: X9

This signal turns on when the data backup/restoration is performed on the CPU module that does not support the data backup/restoration.

■Turning off of 'Backup/Restore unsupported error' (X9)

Perform either of the following operations. Until then, 'Backup/Restore unsupported error' (X9) remains on.

- Reset the CPU module or power off and on the system.
- Turn on and off 'Error flag clear command' (Y0).

Parameter access flag (with handshake): XA

The RJ51AW12AL that supports 'Parameter accessing flag (with handshake)' (XB) is continuously on.

Parameter accessing flag (with handshake): XB

This signal turns on when any of the following output signals is turned on to start the parameter access processing.

- 'Parameter access request command for the slave module' (Y10)
- 'Parameter batch read command for the slave module' (Y11)
- 'Parameter batch write command for the slave module' (Y12)

■Turning off of 'Parameter accessing flag (with handshake)' (XB)

'Parameter accessing flag (with handshake)' (XB) turns off when both of the following conditions are met.

- The parameter access processing has been completed.
- 'Parameter access request command for the slave module' (Y10), 'Parameter batch read command for the slave module' (Y11), and 'Parameter batch write command for the slave module' (Y12) are all turned off.

For the completion timing of the parameter access processing, refer to the following.

☞ Page 38 Check of the parameter access completion

AnyWireASLINK version compatibility inspection executing flag: XD

This signal turns on when the AnyWireASLINK version compatibility inspection is started.

■Turning off of 'AnyWireASLINK version compatibility inspection executing flag' (XD)

'AnyWireASLINK version compatibility inspection executing flag' (XD) turns off when both of the following conditions are met.

- The AnyWireASLINK version compatibility inspection has completed.
- 'AnyWireASLINK version compatibility inspection command' (YD) is turned on and off.

Adjustment mode executing flag: XF

This flag turns on when the ASLINKMONITOR is in the adjustment mode.

The parameter access stops during the adjustment mode.

■Turning off of 'Adjustment mode executing flag (XF)'

'Adjustment mode executing flag (XF)' turns off when the following conditions are met.

- The ASLINKMONITOR is turned into the normal mode.
- The ASLINKMONITOR in the adjustment mode is disconnected.

Slave module alarm signal: X10

This signal turns on when any of the following errors occurs.

- A status error, such as an I/O disconnection or short circuit, occurs in a slave module.
- An error occurs in the slave module address setting.
- When a slave module is replaced using the easy replacement function for one slave module, the model name of the new slave module is different from that of the old slave module.

For details on the target slave module's addresses and alarms, refer to 'Number of the alarm IDs' (Un\G9984) and 'Alarm ID information storage area' (Un\G9985 to Un\G10112). (☞ Page 102 Number of the alarm IDs, Page 103 Alarm ID information storage area)

■Turning off of 'Slave module alarm signal' (X10)

After eliminating the status error of the slave module or setting the address of the slave module again, perform either of the following operations. Until then, 'Slave module alarm signal' (X10) remains on.

- Reset the CPU module or power off and on the system.
- Turn on and off 'Error flag clear command' (Y0).

For how to eliminate the status error in the slave module, refer to the following.

☞ Page 80 List of Error Codes

Parameter access completion flag: X11

This signal turns on and off in any of the following cases and turns off and on when the relevant operation has completed.

- During the parameter access
- During the easy replacement for one slave module
- During the AnyWireASLINK version compatibility inspection

Parameter access error: X12

This signal turns on when an error occurs in the parameter access.

The latest error codes are stored in 'Latest error code storage area' (Un\G10256) and the target IDs of the error codes are stored in 'Latest error ID storage area' (Un\G10257).

■Turning off of 'Parameter access error' (X12)

After the error is cleared, execute any of the following operations. Until then, 'Parameter access error' (X12) remains on.* 1

- Reset the CPU module or power off and on the system.
- Turn on and off 'Error flag clear command' (Y0).

For how to eliminate the parameter access error, refer to the following.

☞ Page 80 List of Error Codes

*1 If the error status automatic recovery function is enabled, this signal turns automatically off.

Automatic address detection flag: X14

The signal remains on from a start of execution of automatic address detection to the end of the execution.

Overlap address inspection flag: X15

The signal remains on from a start of execution of same address used check to the end of the execution.

One slave module changing flag: X16

This flag turns on during the slave module replacement using the easy replacement function for one slave module.

Slave module replacement completion flag: X17

This flag turns on when 'One slave module changing flag' (X16) turns off during the slave module replacement using the easy replacement function for one slave module.

■Turning off of 'Slave module replacement completion flag' (X17)

'Slave module replacement completion flag' (X17) is on for five seconds and then turns off.

Details of the output signal

The following shows the on/off timing or condition of the output signal.

Error flag clear command: Y0

When 'Error flag clear command' (Y0) is turned off and on, the following input signals and the buffer memory areas are cleared.

Type	Item	Operation
Input signal	<ul style="list-style-type: none"> • 'DP/DN short error' (X1) • '24V/DP short error' (X2) • 'Transmission cable voltage drop error' (X3) • 'DP/DN disconnection error' (X4) • 'AnyWireASLINK version compatibility inspection error' (X8) • 'Backup/Restore unsupported error' (X9) • 'Slave module alarm signal' (X10) • 'Parameter access error' (X12) 	The input signal is turned on and off.
Buffer memory area	<ul style="list-style-type: none"> • 'Number of the error IDs' (Un\G8192) • 'Error ID information storage area' (Un\G8193 to Un\G8320) • 'Error ID information bit area (bit output)' (Un\G8704 to Un\G8719) • 'Error ID information bit area (bit input)' (Un\G8736 to Un\G8751) • 'Error ID information bit area (word output)' (Un\G8768 to Un\G8799) • 'Error ID information bit area (word input)' (Un\G8800 to Un\G8831) • 'Number of the alarm IDs' (Un\G9984) • 'Alarm ID information storage area' (Un\G9985 to Un\G10112) • 'Latest error code storage area' (Un\G10256) • 'Latest error ID storage area' (Un\G10257) • 'Event code for sub information area' (Un\G12096) • 'Sub information area' (Un\G12097 to Un\G12224) 	Zero is stored as the value of the buffer memory area.

Resetting the CPU module or turning off and on the power supply also clears the input signals and the buffer memory areas shown above.

Automatic address detection command: Y1

Turn on this signal to execute automatic address detection.

Overlap address inspection command: Y2

Turn on this signal to execute same address used check.

AnyWireASLINK version compatibility inspection command: YD

Turn on this signal to execute the AnyWireASLINK version compatibility inspection.

Parameter access request command for the slave module: Y10

Turn on this signal to perform the following operations from the RJ51AW12AL to a slave module.

- Read and write the parameter of the slave module.
- Execute the remote address change function.

Parameter batch read command for the slave module: Y11

Turn on this signal to collectively read parameters from all slave modules that the RJ51AW12AL recognizes.

Parameter batch write command for the slave module: Y12

Turn on this signal to collectively write parameters to all slave modules that the RJ51AW12AL recognizes.

Appendix 3 Buffer Memory

Buffer memory is for data communications between the RJ51AW12AL and the CPU module or the RJ51AW12AL and slave modules.

When the CPU module is reset or the system is powered off and on, the data in the buffer memory are set back to the default (initial values).

List of buffer memory addresses

Address (decimal)	Address (hexadecimal)	Name	Initial value	Read/write
0 to 15	0H to FH	Bit input information area	0	Read
16 to 511	10H to 1FFH	System area		
512 to 1023	200H to 3FFH	Word input information area ^{*1}	0	Read
1024 to 4095	400H to FFFH	System area		
4096 to 4111	1000H to 100FH	Bit output information area	0	Read/write
4112 to 4607	1010H to 11FFH	System area		
4608 to 5119	1200H to 13FFH	Word output information area ^{*1}	0	Read/write
5120 to 8191	1400H to 1FFFH	System area		
8192	2000H	Number of the error IDs	0	Read
8193 to 8320	2001H to 2080H	Error ID information storage area	0	Read
8321 to 8703	2081H to 21FFH	System area		
8704 to 8719	2200H to 220FH	Error ID information bit area (bit output)	0	Read
8720 to 8735	2210H to 221FH	System area		
8736 to 8751	2220H to 222FH	Error ID information bit area (bit input)	0	Read
8752 to 8767	2230H to 223FH	System area		
8768 to 8799	2240H to 225FH	Error ID information bit area (word output) ^{*1}	0	Read
8800 to 8831	2260H to 227FH	Error ID information bit area (word input) ^{*1}	0	Read
8832 to 8959	2280H to 22FFH	System area		
8960	2300H	Number of the connected modules	0	Read
8961 to 9215	2301H to 23FFH	System area		
9216	2400H	Number of the IDs of the connected modules	0	Read
9217 to 9344	2401H to 2480H	Connected module ID information storage area	0	Read
9345 to 9983	2481H to 26FFH	System area		
9984	2700H	Number of the alarm IDs	0	Read
9985 to 10112	2701H to 2780H	Alarm ID information storage area	0	Read
10113 to 10255	2781H to 280FH	System area		
10256	2810H	Latest error code storage area	0	Read
10257	2811H	Latest error ID storage area	0	Read
10258 to 10319	2812H to 284FH	System area		
10320	2850H	Parameter access setting	0	Read/write
10321	2851H	Parameter access target module ID specification	0	Read/write
10322	2852H	System area		
10323	2853H	Change ID specification	0	Read/write
10324 to 10495	2854H to 28FFH	System area		
10496 to 10751	2900H to 29FFH	Parameter storage location memory number (bit output)	0	Read
10752 to 11007	2A00H to 2AFFH	System area		
11008 to 11263	2B00H to 2BFFH	Parameter storage location memory number (bit input)	0	Read
11264 to 12095	2C00H to 2F3FH	System area		
12096	2F40H	Event code for sub information area ^{*1}	0	Read
12097 to 12224	2F41H to 2FC0H	Sub information area ^{*1}	0	Read
12225 to 12287	2FC1H to 2FFFH	System area		

Address (decimal)	Address (hexadecimal)	Name	Initial value	Read/write
12288 to 18431	3000H to 47FFH	Parameter storage area	0	Read/write
18432 to 19455	4800H to 4BFFH	System area		
19456 to 19967	4C00H to 4DFFH	Parameter storage location memory number (word output) ^{*1}	0	Read
19968 to 20479	4E00H to 4FFFH	Parameter storage location memory number (word input) ^{*1}	0	Read
20480 to 31487	5000H to 7AFFH	System area		
31488	7B00H	Number of word data points setting ^{*1}	0	Read/write
31489	7B01H	System area		
31490	7B02H	Word data start address setting ^{*1}	0	Read/write
31491	7B03H	System area		
31492	7B04H	Number of word data points per frame setting ^{*1}	0	Read/write
31493	7B05H	Number of word data cycles setting ^{*1}	0	Read/write
31494 to 32767	7B06H to 7FFFH	System area		

*1 This signal is usable on the RJ51AW12AL of which first two digits of the production information are "03" or later.



Do not write data to "System area".
Doing so may cause malfunction of the programmable controller system.

Details of buffer memory addresses

Input information area

This buffer memory area automatically stores the on/off status of the input signal of the slave module.

■Bit input information area (Un\G0 to Un\G15)

Address	Input information area*1															
	b15	b14	b13	b12	b11	b10	b9	b8	b7	b6	b5	b4	b3	b2	b1	b0
Un\G0	15	14	13	12	11	10	9	8	7	6	5	4	3	2	1	0
Un\G1	31	30	29	28	27	26	25	24	23	22	21	20	19	18	17	16
Un\G2	47	46	45	44	43	42	41	40	39	38	37	36	35	34	33	32
Un\G3	63	62	61	60	59	58	57	56	55	54	53	52	51	50	49	48
Un\G4	79	78	77	76	75	74	73	72	71	70	69	68	67	66	65	64
Un\G5	95	94	93	92	91	90	89	88	87	86	85	84	83	82	81	80
Un\G6	111	110	109	108	107	106	105	104	103	102	101	100	99	98	97	96
Un\G7	127	126	125	124	123	122	121	120	119	118	117	116	115	114	113	112
Un\G8	143	142	141	140	139	138	137	136	135	134	133	132	131	130	129	128
Un\G9	159	158	157	156	155	154	153	152	151	150	149	148	147	146	145	144
Un\G10	175	174	173	172	171	170	169	168	167	166	165	164	163	162	161	160
Un\G11	191	190	189	188	187	186	185	184	183	182	181	180	179	178	177	176
Un\G12	207	206	205	204	203	202	201	200	199	198	197	196	195	194	193	192
Un\G13	223	222	221	220	219	218	217	216	215	214	213	212	211	210	209	208
Un\G14	239	238	237	236	235	234	233	232	231	230	229	228	227	226	225	224
Un\G15	255	254	253	252	251	250	249	248	247	246	245	244	243	242	241	240

*1 Values in the table indicate the start addresses of the slave modules.

Ex.

When the address of the 2-point bit input slave module is set to 30, b14 to b15 in Un\G1 are occupied as the input signal. When the address of the 16-point bit input slave module is set to 50, b2 to b15 in Un\G3 and b0 to b1 in Un\G4 are occupied as the input signal.

■Word input information area (Un\G512 to Un\G1023)

Address	Input information area*1
Un\G512	0
Un\G513	1
Un\G514	2
Un\G515	3
Un\G516	4
⋮	⋮
Un\G1020	508
Un\G1021	509
Un\G1022	510
Un\G1023	511

*1 Values in the table indicate the start addresses of the slave modules.

Ex.

When the address of the 2-word word input slave module is set to 3, Un\G515 to Un\G516 are occupied as the input signal.

Output information area

When the on/off data of an output signal of a slave module is written from the CPU module, the slave module automatically outputs a signal.

Bit output information area (Un\G4096 to Un\G4111)

Address	Output information area*1															
	b15	b14	b13	b12	b11	b10	b9	b8	b7	b6	b5	b4	b3	b2	b1	b0
Un\G4096	15	14	13	12	11	10	9	8	7	6	5	4	3	2	1	0
Un\G4097	31	30	29	28	27	26	25	24	23	22	21	20	19	18	17	16
Un\G4098	47	46	45	44	43	42	41	40	39	38	37	36	35	34	33	32
Un\G4099	63	62	61	60	59	58	57	56	55	54	53	52	51	50	49	48
Un\G4100	79	78	77	76	75	74	73	72	71	70	69	68	67	66	65	64
Un\G4101	95	94	93	92	91	90	89	88	87	86	85	84	83	82	81	80
Un\G4102	111	110	109	108	107	106	105	104	103	102	101	100	99	98	97	96
Un\G4103	127	126	125	124	123	122	121	120	119	118	117	116	115	114	113	112
Un\G4104	143	142	141	140	139	138	137	136	135	134	133	132	131	130	129	128
Un\G4105	159	158	157	156	155	154	153	152	151	150	149	148	147	146	145	144
Un\G4106	175	174	173	172	171	170	169	168	167	166	165	164	163	162	161	160
Un\G4107	191	190	189	188	187	186	185	184	183	182	181	180	179	178	177	176
Un\G4108	207	206	205	204	203	202	201	200	199	198	197	196	195	194	193	192
Un\G4109	223	222	221	220	219	218	217	216	215	214	213	212	211	210	209	208
Un\G4110	239	238	237	236	235	234	233	232	231	230	229	228	227	226	225	224
Un\G4111	255	254	253	252	251	250	249	248	247	246	245	244	243	242	241	240

*1 Values in the table indicate the start addresses of the slave modules.

Ex.

When the address of the 2-point bit output slave module is set to 30, b14 to b15 in Un\G4097 are occupied as the output signal.

When the address of the 16-point bit output slave module is set to 50, b2 to b15 in Un\G4099 and b0 to b1 in Un\G4100 are occupied as the output signal.

Word output information area (Un\G4608 to Un\G5119)

Address	Output information area*1
Un\G4608	0
Un\G4609	1
Un\G4610	2
Un\G4611	3
Un\G4612	4
⋮	⋮
Un\G5116	508
Un\G5117	509
Un\G5118	510
Un\G5119	511

*1 Values in the table indicate the start addresses of the slave modules.

Ex.

When the address of the 2-word word output slave module is set to 508, Un\G5116 to Un\G5117 are occupied as the output signal.

A

Number of the error IDs

■Number of the error IDs (Un\G8192)

This buffer memory area stores the number of error IDs that send no response due to disconnection of the transmission cable (DP, DN) or a failure in the slave module alone among the IDs of the connected modules. (Up to 128 IDs)

The stored values are retained until the power is turned off and on or 'Error flag clear command' (Y0) is turned off and on after the error is cleared.

However, if the error status automatic recovery function is enabled, the number of slave modules (number of error IDs) from which errors are cleared automatically decreases.

Data update timing

After automatic address detection, the data are updated as soon as a response error is detected.

Error ID information storage area

■Error ID information storage area (Un\G8193 to Un\G8320)

When the transmission cables (DP, DN) are disconnected or an error in a slave module or an error (error code: 0CCA, 0D30) occurs, this buffer memory area stores all the error IDs in the ascending order. (Up to 128 IDs)

The IDs to be stored are as follows.

- 0000H to 00FEH: ID of a bit output slave module
- 0200H to 02FEH: ID of a bit input slave module or bit I/O combined slave module
- 0400H to 05FEH: ID of a word output slave module
- 0600H to 07FEH: ID of a word input slave module or word I/O combined slave module
- 00FFH: Unset IDs of bit output slave modules and word output slave modules
- 02FFH: Unset IDs of bit input slave modules and word input slave modules

The stored values are retained until the power is turned off and on or 'Error flag clear command' (Y0) is turned off and on after the error is cleared.

However, if the error status automatic recovery function is enabled, the ID of a slave module from which an error is cleared turns off automatically.

Data update timing

After automatic address detection, the data are updated as soon as a response error is detected.

Error ID information bit area

These buffer memory areas show error IDs in units of bits for reference. These areas are used in the same manner as 'Error ID information storage area' (Un\G8193 to Un\G8320).

■Error ID information bit area (bit output) (Un\G8704 to Un\G8719)

The bits of error IDs corresponding to the bit output slave module turn on.

Address*1	b15	b14	b13	b12	b11	b10	b9	b8	b7	b6	b5	b4	b3	b2	b1	b0
Un\G8704	FH	EH	DH	CH	BH	AH	9H	8H	7H	6H	5H	4H	3H	2H	1H	0H
Un\G8705	1FH	1EH	1DH	1CH	1BH	1AH	19H	18H	17H	16H	15H	14H	13H	12H	11H	10H
Un\G8706	2FH	2EH	2DH	2CH	2BH	2AH	29H	28H	27H	26H	25H	24H	23H	22H	21H	20H
Un\G8707	3FH	3EH	3DH	3CH	3BH	3AH	39H	38H	37H	36H	35H	34H	33H	32H	31H	30H
Un\G8708	4FH	4EH	4DH	4CH	4BH	4AH	49H	48H	47H	46H	45H	44H	43H	42H	41H	40H
Un\G8709	5FH	5EH	5DH	5CH	5BH	5AH	59H	58H	57H	56H	55H	54H	53H	52H	51H	50H
Un\G8710	6FH	6EH	6DH	6CH	6BH	6AH	69H	68H	67H	66H	65H	64H	63H	62H	61H	60H
Un\G8711	7FH	7EH	7DH	7CH	7BH	7AH	79H	78H	77H	76H	75H	74H	73H	72H	71H	70H
Un\G8712	8FH	8EH	8DH	8CH	8BH	8AH	89H	88H	87H	86H	85H	84H	83H	82H	81H	80H
Un\G8713	9FH	9EH	9DH	9CH	9BH	9AH	99H	98H	97H	96H	95H	94H	93H	92H	91H	90H
Un\G8714	AFH	AEH	ADH	ACH	ABH	AAH	A9H	A8H	A7H	A6H	A5H	A4H	A3H	A2H	A1H	A0H
Un\G8715	BFH	BEH	BDH	BCH	BBH	BAH	B9H	B8H	B7H	B6H	B5H	B4H	B3H	B2H	B1H	B0H
Un\G8716	CFH	CEH	CDH	CCH	CBH	CAH	C9H	C8H	C7H	C6H	C5H	C4H	C3H	C2H	C1H	C0H
Un\G8717	DFH	DEH	DDH	DCH	DBH	DAH	D9H	D8H	D7H	D6H	D5H	D4H	D3H	D2H	D1H	D0H
Un\G8718	EFH	EEH	EDH	ECH	EBH	EAH	E9H	E8H	E7H	E6H	E5H	E4H	E3H	E2H	E1H	E0H
Un\G8719	FFH	FEH	FDH	FCH	FBH	FAH	F9H	F8H	F7H	F6H	F5H	F4H	F3H	F2H	F1H	F0H

*1 Values in the table indicate the slave module ID.

■Error ID information bit area (bit input) (Un\G8736 to Un\G8751)

The bits of error IDs corresponding to the bit input slave module or bit I/O combined slave module turn on.

Address*1	b15	b14	b13	b12	b11	b10	b9	b8	b7	b6	b5	b4	b3	b2	b1	b0
Un\G8736	20FH	20EH	20DH	20CH	20BH	20AH	209H	208H	207H	206H	205H	204H	203H	202H	201H	200H
Un\G8737	21FH	21EH	21DH	21CH	21BH	21AH	219H	218H	217H	216H	215H	214H	213H	212H	211H	210H
Un\G8738	22FH	22EH	22DH	22CH	22BH	22AH	229H	228H	227H	226H	225H	224H	223H	222H	221H	220H
Un\G8739	23FH	23EH	23DH	23CH	23BH	23AH	239H	238H	237H	236H	235H	234H	233H	232H	231H	230H
Un\G8740	24FH	24EH	24DH	24CH	24BH	24AH	249H	248H	247H	246H	245H	244H	243H	242H	241H	240H
Un\G8741	25FH	25EH	25DH	25CH	25BH	25AH	259H	258H	257H	256H	255H	254H	253H	252H	251H	250H
Un\G8742	26FH	26EH	26DH	26CH	26BH	26AH	269H	268H	267H	266H	265H	264H	263H	262H	261H	260H
Un\G8743	27FH	27EH	27DH	27CH	27BH	27AH	279H	278H	277H	276H	275H	274H	273H	272H	271H	270H
Un\G8744	28FH	28EH	28DH	28CH	28BH	28AH	289H	288H	287H	286H	285H	284H	283H	282H	281H	280H
Un\G8745	29FH	29EH	29DH	29CH	29BH	29AH	299H	298H	297H	296H	295H	294H	293H	292H	291H	290H
Un\G8746	2AFH	2AEH	2ADH	2ACH	2ABH	2AAH	2A9H	2A8H	2A7H	2A6H	2A5H	2A4H	2A3H	2A2H	2A1H	2A0H
Un\G8747	2BFH	2BEH	2BDH	2BCH	2BBH	2BAH	2B9H	2B8H	2B7H	2B6H	2B5H	2B4H	2B3H	2B2H	2B1H	2B0H
Un\G8748	2CFH	2CEH	2CDH	2CCH	2CBH	2CAH	2C9H	2C8H	2C7H	2C6H	2C5H	2C4H	2C3H	2C2H	2C1H	2C0H
Un\G8749	2DFH	2DEH	2DDH	2DCH	2DBH	2DAH	2D9H	2D8H	2D7H	2D6H	2D5H	2D4H	2D3H	2D2H	2D1H	2D0H
Un\G8750	2EFH	2EEH	2EDH	2ECH	2EBH	2EAH	2E9H	2E8H	2E7H	2E6H	2E5H	2E4H	2E3H	2E2H	2E1H	2E0H
Un\G8751	2FFH	2FEH	2FDH	2FCH	2FBH	2FAH	2F9H	2F8H	2F7H	2F6H	2F5H	2F4H	2F3H	2F2H	2F1H	2F0H

*1 Values in the table indicate the slave module ID.

■ Error ID information bit area (word output) (Un\G8768 to Un\G8799)

The bits of error IDs corresponding to the word output slave module turn on.

Address*1	b15	b14	b13	b12	b11	b10	b9	b8	b7	b6	b5	b4	b3	b2	b1	b0
Un\G8768	40FH	40EH	40DH	40CH	40BH	40AH	409H	408H	407H	406H	405H	404H	403H	402H	401H	400H
Un\G8769	41FH	41EH	41DH	41CH	41BH	41AH	419H	418H	417H	416H	415H	414H	413H	412H	411H	410H
Un\G8770	42FH	42EH	42DH	42CH	42BH	42AH	429H	428H	427H	426H	425H	424H	423H	422H	421H	420H
Un\G8771	43FH	43EH	43DH	43CH	43BH	43AH	439H	438H	437H	436H	435H	434H	433H	432H	431H	430H
Un\G8772	44FH	44EH	44DH	44CH	44BH	44AH	449H	448H	447H	446H	445H	444H	443H	442H	441H	440H
Un\G8773	45FH	45EH	45DH	45CH	45BH	45AH	459H	458H	457H	456H	455H	454H	453H	452H	451H	450H
Un\G8774	46FH	46EH	46DH	46CH	46BH	46AH	469H	468H	467H	466H	465H	464H	463H	462H	461H	460H
Un\G8775	47FH	47EH	47DH	47CH	47BH	47AH	479H	478H	477H	476H	475H	474H	473H	472H	471H	470H
Un\G8776	48FH	48EH	48DH	48CH	48BH	48AH	489H	488H	487H	486H	485H	484H	483H	482H	481H	480H
Un\G8777	49FH	49EH	49DH	49CH	49BH	49AH	499H	498H	497H	496H	495H	494H	493H	492H	491H	490H
Un\G8778	4AFH	4AEH	4ADH	4ACH	4ABH	4AAH	4A9H	4A8H	4A7H	4A6H	4A5H	4A4H	4A3H	4A2H	4A1H	4A0H
Un\G8779	4BFH	4BEH	4BDH	4BCH	4BBH	4BAH	4B9H	4B8H	4B7H	4B6H	4B5H	4B4H	4B3H	4B2H	4B1H	4B0H
Un\G8780	4CFH	4CEH	4CDH	4CCH	4CBH	4CAH	4C9H	4C8H	4C7H	4C6H	4C5H	4C4H	4C3H	4C2H	4C1H	4C0H
Un\G8781	4DFH	4DEH	4DDH	4DCH	4DBH	4DAH	4D9H	4D8H	4D7H	4D6H	4D5H	4D4H	4D3H	4D2H	4D1H	4D0H
Un\G8782	4EFH	4EEH	4EDH	4ECH	4EBH	4EAH	4E9H	4E8H	4E7H	4E6H	4E5H	4E4H	4E3H	4E2H	4E1H	4E0H
Un\G8783	4FFH	4FEH	4FDH	4FCH	4FBH	4FAH	4F9H	4F8H	4F7H	4F6H	4F5H	4F4H	4F3H	4F2H	4F1H	4F0H
Un\G8784	50FH	50EH	50DH	50CH	50BH	50AH	509H	508H	507H	506H	505H	504H	503H	502H	501H	500H
Un\G8785	51FH	51EH	51DH	51CH	51BH	51AH	519H	518H	517H	516H	515H	514H	513H	512H	511H	510H
Un\G8786	52FH	52EH	52DH	52CH	52BH	52AH	529H	528H	527H	526H	525H	524H	523H	522H	521H	520H
Un\G8787	53FH	53EH	53DH	53CH	53BH	53AH	539H	538H	537H	536H	535H	534H	533H	532H	531H	530H
Un\G8788	54FH	54EH	54DH	54CH	54BH	54AH	549H	548H	547H	546H	545H	544H	543H	542H	541H	540H
Un\G8789	55FH	55EH	55DH	55CH	55BH	55AH	559H	558H	557H	556H	555H	554H	553H	552H	551H	550H
Un\G8790	56FH	56EH	56DH	56CH	56BH	56AH	569H	568H	567H	566H	565H	564H	563H	562H	561H	560H
Un\G8791	57FH	57EH	57DH	57CH	57BH	57AH	579H	578H	577H	576H	575H	574H	573H	572H	571H	570H
Un\G8792	58FH	58EH	58DH	58CH	58BH	58AH	589H	588H	587H	586H	585H	584H	583H	582H	581H	580H
Un\G8793	59FH	59EH	59DH	59CH	59BH	59AH	599H	598H	597H	596H	595H	594H	593H	592H	591H	590H
Un\G8794	5AFH	5AEH	5ADH	5ACH	5ABH	5AAH	5A9H	5A8H	5A7H	5A6H	5A5H	5A4H	5A3H	5A2H	5A1H	5A0H
Un\G8795	5BFH	5BEH	5BDH	5BCH	5BBH	5BAH	5B9H	5B8H	5B7H	5B6H	5B5H	5B4H	5B3H	5B2H	5B1H	5B0H
Un\G8796	5CFH	5CEH	5CDH	5CCH	5CBH	5CAH	5C9H	5C8H	5C7H	5C6H	5C5H	5C4H	5C3H	5C2H	5C1H	5C0H
Un\G8797	5DFH	5DEH	5DDH	5DCH	5DBH	5DAH	5D9H	5D8H	5D7H	5D6H	5D5H	5D4H	5D3H	5D2H	5D1H	5D0H
Un\G8798	5EFH	5EEH	5EDH	5ECH	5EBH	5EAH	5E9H	5E8H	5E7H	5E6H	5E5H	5E4H	5E3H	5E2H	5E1H	5E0H
Un\G8799	5FFH	5FEH	5FDH	5FCH	5FBH	5FAH	5F9H	5F8H	5F7H	5F6H	5F5H	5F4H	5F3H	5F2H	5F1H	5F0H

*1 Values in the table indicate the slave module ID.

■ Error ID information bit area (word input) (Un\G8800 to Un\G8831)

The bits of error IDs corresponding to the word input slave module or word I/O combined slave module turn on.

Address*1	b15	b14	b13	b12	b11	b10	b9	b8	b7	b6	b5	b4	b3	b2	b1	b0
Un\G8800	60FH	60EH	60DH	60CH	60BH	60AH	609H	608H	607H	606H	605H	604H	603H	602H	601H	600H
Un\G8801	61FH	61EH	61DH	61CH	61BH	61AH	619H	618H	617H	616H	615H	614H	613H	612H	611H	610H
Un\G8802	62FH	62EH	62DH	62CH	62BH	62AH	629H	628H	627H	626H	625H	624H	623H	622H	621H	620H
Un\G8803	63FH	63EH	63DH	63CH	63BH	63AH	639H	638H	637H	636H	635H	634H	633H	632H	631H	630H
Un\G8804	64FH	64EH	64DH	64CH	64BH	64AH	649H	648H	647H	646H	645H	644H	643H	642H	641H	640H
Un\G8805	65FH	65EH	65DH	65CH	65BH	65AH	659H	658H	657H	656H	655H	654H	653H	652H	651H	650H
Un\G8806	66FH	66EH	66DH	66CH	66BH	66AH	669H	668H	667H	666H	665H	664H	663H	662H	661H	660H
Un\G8807	67FH	67EH	67DH	67CH	67BH	67AH	679H	678H	677H	676H	675H	674H	673H	672H	671H	670H
Un\G8808	68FH	68EH	68DH	68CH	68BH	68AH	689H	688H	687H	686H	685H	684H	683H	682H	681H	680H
Un\G8809	69FH	69EH	69DH	69CH	69BH	69AH	699H	698H	697H	696H	695H	694H	693H	692H	691H	690H
Un\G8810	6AFH	6AEH	6ADH	6ACH	6ABH	6AAH	6A9H	6A8H	6A7H	6A6H	6A5H	6A4H	6A3H	6A2H	6A1H	6A0H
Un\G8811	6BFH	6BEH	6BDH	6BCH	6BBH	6BAH	6B9H	6B8H	6B7H	6B6H	6B5H	6B4H	6B3H	6B2H	6B1H	6B0H
Un\G8812	6CFH	6CEH	6CDH	6CCH	6CBH	6CAH	6C9H	6C8H	6C7H	6C6H	6C5H	6C4H	6C3H	6C2H	6C1H	6C0H
Un\G8813	6DFH	6DEH	6DDH	6DCH	6DBH	6DAH	6D9H	6D8H	6D7H	6D6H	6D5H	6D4H	6D3H	6D2H	6D1H	6D0H
Un\G8814	6EFH	6EEH	6EDH	6ECH	6EBH	6EAH	6E9H	6E8H	6E7H	6E6H	6E5H	6E4H	6E3H	6E2H	6E1H	6E0H
Un\G8815	6FFH	6FEH	6FDH	6FCH	6FBH	6FAH	6F9H	6F8H	6F7H	6F6H	6F5H	6F4H	6F3H	6F2H	6F1H	6F0H
Un\G8816	70FH	70EH	70DH	70CH	70BH	70AH	709H	708H	707H	706H	705H	704H	703H	702H	701H	700H
Un\G8817	71FH	71EH	71DH	71CH	71BH	71AH	719H	718H	717H	716H	715H	714H	713H	712H	711H	710H
Un\G8818	72FH	72EH	72DH	72CH	72BH	72AH	729H	728H	727H	726H	725H	724H	723H	722H	721H	720H
Un\G8819	73FH	73EH	73DH	73CH	73BH	73AH	739H	738H	737H	736H	735H	734H	733H	732H	731H	730H
Un\G8820	74FH	74EH	74DH	74CH	74BH	74AH	749H	748H	747H	746H	745H	744H	743H	742H	741H	740H
Un\G8821	75FH	75EH	75DH	75CH	75BH	75AH	759H	758H	757H	756H	755H	754H	753H	752H	751H	750H
Un\G8822	76FH	76EH	76DH	76CH	76BH	76AH	769H	768H	767H	766H	765H	764H	763H	762H	761H	760H
Un\G8823	77FH	77EH	77DH	77CH	77BH	77AH	779H	778H	777H	776H	775H	774H	773H	772H	771H	770H
Un\G8824	78FH	78EH	78DH	78CH	78BH	78AH	789H	788H	787H	786H	785H	784H	783H	782H	781H	780H
Un\G8825	79FH	79EH	79DH	79CH	79BH	79AH	799H	798H	797H	796H	795H	794H	793H	792H	791H	790H
Un\G8826	7AFH	7AEH	7ADH	7ACH	7ABH	7AAH	7A9H	7A8H	7A7H	7A6H	7A5H	7A4H	7A3H	7A2H	7A1H	7A0H
Un\G8827	7BFH	7BEH	7BDH	7BCH	7BBH	7BAH	7B9H	7B8H	7B7H	7B6H	7B5H	7B4H	7B3H	7B2H	7B1H	7B0H
Un\G8828	7CFH	7CEH	7CDH	7CCH	7CBH	7CAH	7C9H	7C8H	7C7H	7C6H	7C5H	7C4H	7C3H	7C2H	7C1H	7C0H
Un\G8829	7DFH	7DEH	7DDH	7DCH	7DBH	7DAH	7D9H	7D8H	7D7H	7D6H	7D5H	7D4H	7D3H	7D2H	7D1H	7D0H
Un\G8830	7EFH	7EEH	7EDH	7ECH	7EBH	7EAH	7E9H	7E8H	7E7H	7E6H	7E5H	7E4H	7E3H	7E2H	7E1H	7E0H
Un\G8831	7FFH	7FEH	7FDH	7FCH	7FBH	7FAH	7F9H	7F8H	7F7H	7F6H	7F5H	7F4H	7F3H	7F2H	7F1H	7F0H

*1 Values in the table indicate the slave module ID.

Number of the connected modules

■Number of the connected modules (Un\G8960)

This buffer memory area stores the number of slave modules detected by automatic address detection. (Up to 128 modules)

Number of the IDs of the connected modules

■Number of the IDs of the connected modules (Un\G9216)

This buffer memory area stores the number of IDs of the connected modules through automatic address detection. (Up to 128 IDs)

The number of stored IDs is retained even after the power supply is turned off.

Data update timing

The data are updated at the time of power-on or automatic address detection.

Connected module ID information storage area

■Connected module ID information storage area (Un\G9217 to Un\G9344)

This buffer memory area stores the ID information of all the slave modules connected to the RJ51AW12AL in the ascending order.

The IDs to be stored are as follows.

- 0000H to 00FEH: ID of a bit output slave module
- 0200H to 02FEH: ID of a bit input slave module or bit I/O combined slave module
- 0400H to 05FEH: ID of a word output slave module
- 0600H to 07FEH: ID of a word input slave module or word I/O combined slave module
- 00FFH: Unset IDs of bit output slave modules and word output slave modules
- 02FFH: Unset IDs of bit input slave modules and word input slave modules

Information of a stored ID is retained even after the power supply is turned off.

Data update timing

The data are updated at the time of power-on or automatic address detection.

Number of the alarm IDs

■Number of the alarm IDs (Un\G9984)

When a status error or parameter setting error occurs in a slave module, this buffer memory area stores the number of IDs relevant to alarm occurrence. (Up to 128 IDs)

The stored values are retained until the power is turned off and on or 'Error flag clear command' (Y0) is turned off and on after the error is cleared.

Data update timing

The data are updated when the power is turned on or when an alarm has occurred after automatic address detection.

The following shows alarm target error codes.

Error code	Error description
0D2CH, 0D2DH	Slave module hardware error
0D2FH	Parameter value error
0D31H	Slave module status error
0D80H	Type mismatch error
0D90H	Same ID used error
0D91H	No ID setting error

Alarm ID information storage area

■ Alarm ID information storage area (Un\G9985 to Un\G10112)

This buffer memory area stores the ID information of all the slave modules where an alarm has occurred in the ascending order.

The IDs to be stored are as follows.

- 0000H to 00FEH: ID of a bit output slave module
- 0200H to 02FEH: ID of a bit input slave module or bit I/O combined slave module
- 0400H to 05FEH: ID of a word output slave module
- 0600H to 07FEH: ID of a word input slave module or word I/O combined slave module
- 00FFH: Unset IDs of bit output slave modules and word output slave modules
- 02FFH: Unset IDs of bit input slave modules and word input slave modules

The stored values are retained until the power is turned off and on or 'Error flag clear command' (Y0) is turned off and on after the error is cleared.

Data update timing

The data are updated when the power is turned on or when an alarm has occurred after automatic address detection.

Latest error code storage area

■ Latest error code storage area (Un\G10256)

This buffer memory area stores the latest error code detected in the RJ51AW12AL. For details on the error codes, refer to the following.

☞ Page 80 List of Error Codes

Latest error ID storage area

■ Latest error ID storage area (Un\G10257)

This buffer memory area stores the IDs corresponding to the error codes stored in 'Latest error code storage area' (Un\G10256).

However, for the errors below, "0FFFFH" is stored.

Error code	Error description
0CC8H	Transmission cable voltage drop error
0CC9H	DP/DN short error
0CCBH	24V/DP short error
0D2EH	Parameter access target module ID error
0D83H	Non-compatible slave module connection error detected in compatibility inspection
0D84H	Access error detected in compatibility inspection
0D85H	Excessive number of connected slave modules error detected in compatibility inspection
0D92H	New ID error
1867H	EEPROM access error
186EH	EEPROM error (ID, parameter information)
3064H to 3066H	RJ51AW12AL hardware failure
3068H	CPU module stop error (IORSTL signal detection)
3069H	System error (NMI signal detection)
306BH	CPU module error (ITERR signal detection)
306CH	ASIC access error (library I/F function access error)

Parameter access setting

■Parameter access setting (Un\G10320)

Specify the parameter access method. When a value other than those below is stored, the parameter is read.

- 0000H: Read (slave module → RJ51AW12AL → CPU module)
- 0001H: Write (CPU module → RJ51AW12AL → slave module)
- 0002H: Remote address change (CPU module → RJ51AW12AL → slave module)

However, when the output signals below are executed, the set value is ignored.

- 'Parameter batch read command for the slave module' (Y11)
- 'Parameter batch write command for the slave module' (Y12)

Parameter access target module ID specification

■Parameter access target module ID specification (Un\G10321)

Specify the access ID for accessing the parameters of individual IDs.

Write one of the following to specify the ID.

- 0000H to 00FEH: ID of a bit output slave module
- 0200H to 02FEH: ID of a bit input slave module or bit I/O combined slave module
- 0400H to 05FEH: ID of a word output slave module
- 0600H to 07FEH: ID of a word input slave module or word I/O combined slave module

However, when the output signals below are executed, the set value is ignored.

- 'Parameter batch read command for the slave module' (Y11)
- 'Parameter batch write command for the slave module' (Y12)

Change ID specification

■Change ID specification (Un\G10323)

Specify a new ID (address) with the remote address change function.

Write one of the following to specify the ID.

- 0000H to 00FEH: ID of a bit output slave module
- 0200H to 02FEH: ID of a bit input slave module or bit I/O combined slave module
- 0400H to 05FEH: ID of a word output slave module
- 0600H to 07FEH: ID of a word input slave module or word I/O combined slave module

However, when the output signals below are executed, the set value is ignored.

- 'Parameter batch read command for the slave module' (Y11)
- 'Parameter batch write command for the slave module' (Y12)

Parameter storage location memory number

This buffer memory area stores the start addresses of the buffer memory areas of the parameter storage areas for each slave modules.

Parameter storage location memory number (bit output) (Un\G10496 to Un\G10751)

Address	Details
Un\G10496	Buffer memory start address of the bit output slave module ID 0000H
Un\G10497	Buffer memory start address of the bit output slave module ID 0001H
⋮	⋮
Un\G10750	Buffer memory start address of the bit output slave module ID 00FEH
Un\G10751	System area

Parameter storage location memory number (bit input) (Un\G11008 to Un\G11263)

Address	Details
Un\G11008	Buffer memory start address of the bit input slave module or bit I/O combined slave module ID 0200H
Un\G11009	Buffer memory start address of the bit input slave module or bit I/O combined slave module ID 0201H
⋮	⋮
Un\G11262	Buffer memory start address of the bit input slave module or bit I/O combined slave module ID 02FEH
Un\G11263	System area

Parameter storage location memory number (word output) (Un\G19456 to Un\G19967)

Address	Details
Un\G19456	Buffer memory start address of the word output slave module ID 0400H
Un\G19457	Buffer memory start address of the word output slave module ID 0401H
⋮	⋮
Un\G19966	Buffer memory start address of the word output slave module ID 05FEH
Un\G19967	System area

Parameter storage location memory number (word input) (Un\G19968 to Un\G20479)

Address	Details
Un\G19968	Buffer memory start address of the word input slave module or word I/O combined slave module ID 0600H
Un\G19969	Buffer memory start address of the word input slave module or word I/O combined slave module ID 0601H
⋮	⋮
Un\G20478	Buffer memory start address of the word input slave module or word I/O combined slave module ID 07FEH
Un\G20479	System area

Ex.

The following table describes the buffer memory areas corresponding to the addresses of slave modules.

- Address 0: Bit input slave module
- Address 10: Bit output slave module
- Address 100: Bit output slave module

Address	Data ^{*1}	Description
Un\G10506	3000H (12288)	Parameter storage start address of the bit output slave module with the address 10 (ID: 000AH)
Un\G10596	3030H (12336)	Parameter storage start address of the bit output slave module with the address 100 (ID: 0064H)
Un\G11008	3060H (12384)	Parameter storage start address of the bit input slave module with the address 0 (ID: 0200H)

*1 Data stored in the buffer memory address

For example, when "3000H" is stored in the buffer memory address "Un\G10506", it indicates that parameters are stored in the buffer memory addresses "Un\G12288 to Un\G12335".

Point

For the parameter storage location memory number of a non-existing ID, 0000H is stored.

Event code for sub information area

■'Event code for sub information area' (Un\G12096)

This buffer memory area stores the latest event code detected in the RJ51AW12AL. For details on the event code, refer to the following.

☞ Page 84 Event List

■'Sub information area' (Un\G12097 to Un\G12224)

The bits of target IDs for the event code stored in 'Event code for sub information area' (Un\G12096) turn on.

Address *1	b15	b14	b13	b12	b11	b10	b9	b8	b7	b6	b5	b4	b3	b2	b1	b0
Un\G12097	FH	EH	DH	CH	BH	AH	9H	8H	7H	6H	5H	4H	3H	2H	1H	0H
Un\G12098	1FH	1EH	1DH	1CH	1BH	1AH	19H	18H	17H	16H	15H	14H	13H	12H	11H	10H
Un\G12099	2FH	2EH	2DH	2CH	2BH	2AH	29H	28H	27H	26H	25H	24H	23H	22H	21H	20H
⋮	⋮															
Un\G12222	7DFH	7DEH	7DDH	7DCH	7DBH	7DAH	7D9H	7D8H	7D7H	7D6H	7D5H	7D4H	7D3H	7D2H	7D1H	7D0H
Un\G12223	7EFH	7EEH	7EDH	7ECH	7EBH	7EAH	7E9H	7E8H	7E7H	7E6H	7E5H	7E4H	7E3H	7E2H	7E1H	7E0H
Un\G12224	7FFH	7FEH	7FDH	7FCH	7FBH	7FAH	7F9H	7F8H	7F7H	7F6H	7F5H	7F4H	7F3H	7F2H	7F1H	7F0H

*1 Values in the table indicate the slave module ID.

Parameter storage area

This buffer memory area stores parameters for slave modules with IDs.

■Parameter storage area (Un\G12288 to Un\G18431)

Address	Description	Details
Un\G12288 to Un\G12335	Parameter storage area 1 (48 words)	<ul style="list-style-type: none"> The parameter storage area of each ID has 48 words. Information of up to 128 parameters can be stored. The ID is stored in the start address of each parameter area. A single storage area has 48 words and the data are sorted in the ascending order of IDs. When adding a slave module or changing the ID of a slave module, execute automatic address detection again.
Un\G12336 to Un\G12383	Parameter storage area 2 (48 words)	
⋮	⋮	
Un\G18336 to Un\G18383	Parameter storage area 127 (48 words)	
Un\G18384 to Un\G18431	Parameter storage area 128 (48 words)	

Ex.

When five slave modules are connected, the buffer memory addresses of the parameter storage areas are as follows.

Module	Parameter storage area	Device parameter read/write area
First slave module	Un\G12288 to Un\G12335	Un\G12289 to Un\G12307
Second slave module	Un\G12336 to Un\G12383	Un\G12337 to Un\G12355
Third slave module	Un\G12384 to Un\G12431	Un\G12385 to Un\G12403
Fourth slave module	Un\G12432 to Un\G12479	Un\G12433 to Un\G12451
Fifth slave module	Un\G12480 to Un\G12527	Un\G12481 to Un\G12499

The parameter of the slave module is moved over in order of ID and stored in 'Parameter storage area' (Un\G12288 to Un\G18431) after the automatic address detection function is executed.

Because of this, the address of the parameter storage area for the slave module later than the ID where the slave module is added or deleted in the AnyWireASLINK system is changed. (The parameter of a non-existing ID is deleted and displayed.)

Therefore, the address of the slave module later than the ID where the slave module is added or deleted must be changed when a program is created with buffer memory addresses directly specified. (This also applies if the ID is changed and sorting order is switched.)

With the following buffer memory areas, a program that reads/writes the parameter can be created without considering the addition or deletion of slave modules.

Address	Name
Un\G10496 to Un\G10751	Parameter storage location memory number (bit output)
Un\G11008 to Un\G11263	Parameter storage location memory number (bit input)
Un\G19456 to Un\G19967	Parameter storage location memory number (word output)
Un\G19968 to Un\G20479	Parameter storage location memory number (word input)

For details, refer to the following.

☞ Page 63 Communication Example When the Slave Module is Added or Deleted

■48-word structure (details on parameter storage area)

The parameter storage area 1 (Un\G12288 to Un\G12335) is given as an example of the 48-word structure below.

Address	Description	Read/write	Parameter name
Un\G12288	Module ID	Read (Slave module to RJ51AW12AL)	AnyWireASLINK parameter
Un\G12289	Device parameter 1	Read/write (RJ51AW12AL to slave module)	Device parameter
Un\G12290	Device parameter 2		
Un\G12291	Device parameter 3		
Un\G12292	Device parameter 4		
Un\G12293	Device parameter 5		
Un\G12294	Device parameter 6		
Un\G12295	Device parameter 7		
Un\G12296	Device parameter 8		
Un\G12297	Device parameter 9		
Un\G12298	Device parameter 10		
Un\G12299	Device parameter 11		
Un\G12300	Device parameter 12		
Un\G12301	Device parameter 13		
Un\G12302	Device parameter 14		
Un\G12303	Device parameter 15		
Un\G12304	Device parameter 16		
Un\G12305	Device parameter 17		
Un\G12306	Device parameter 18		
Un\G12307	Device parameter 19		
Un\G12308	Device parameter 1	Read (Slave module to RJ51AW12AL)	
Un\G12309	Device parameter 2		
Un\G12310	Device parameter 3		
Un\G12311	Device parameter 4		
Un\G12312	Device parameter 5		
Un\G12313	Device parameter 6		
Un\G12314	Device parameter 7		
Un\G12315	Device parameter 8		
Un\G12316	Device parameter 9		
Un\G12317	Device parameter 10		
Un\G12318	Device parameter 11		
Un\G12319	Device parameter 12		
Un\G12320	Device parameter 13		
Un\G12321	Device parameter 14		
Un\G12322	Device parameter 15		
Un\G12323	Device parameter 16		
Un\G12324	Device parameter 17		
Un\G12325	Device parameter 18		
Un\G12326	Device parameter 19		
Un\G12327	Status details	Read (Slave module to RJ51AW12AL)	AnyWireASLINK parameter
Un\G12328	Sensing level		
Un\G12329 to Un\G12335	System area	—	—

■Parameters

Each slave module has the following types of parameters:

- Device parameter (19 types)

These parameters are unique to each slave module. The contents of the parameters vary depending on the types of slave modules. For details, refer to the specifications of the slave module.

- AnyWireASLINK parameter (3 types)

These parameters are common to all the slave modules connected to AnyWireASLINK.

Name	Read/write	Corresponding buffer memory area	Detailed description
Module ID	Read	Un\G12288+n × 30H (n: 0 to 255) 1st of 48 words	Indicates the slave module ID. <ul style="list-style-type: none"> • 0000H to 00FEH: ID of a bit output slave module • 0200H to 02FEH: ID of a bit input slave module or bit I/O combined slave module • 0400H to 05FEH: ID of a word output slave module • 0600H to 07FEH: ID of a word input slave module or word I/O combined slave module • 00FFH: Unset IDs of bit output slave modules and word output slave modules • 02FFH: Unset IDs of bit input slave modules and word input slave modules
Status details	Read	Un\G12327+n × 30H (n: 0 to 255) 40th of 48 words	Indicates the status of the slave module. The statuses of the slave modules can be checked with the on/off status of each bit. <ul style="list-style-type: none"> ■b0: Module power supply status <ul style="list-style-type: none"> • On: Slave module voltage drop • Off: No error ■b1: Sensing level status <ul style="list-style-type: none"> • On: Sensing level drop • Off: No error ■b2: I/O disconnection (ASLINKER) <ul style="list-style-type: none"> • On: I/O disconnection • Off: No error ■b3: I/O short-circuit (ASLINKER) <ul style="list-style-type: none"> • On: I/O short-circuit • Off: No error ■b4: Measurement alarm <ul style="list-style-type: none"> • On: Alarm • Off: No error ■b5: I/O power supply voltage drop (isolation slave module) <ul style="list-style-type: none"> • On: I/O power supply voltage drop • Off: No error ■b6: System area ■b7: Teaching setting error <ul style="list-style-type: none"> • On: Teaching setting error • Off: No error ■b8 to b13: Differs for each slave module <ul style="list-style-type: none"> • On: Indicates different status depending on the slave module. • Off: Indicates different status depending on the slave module. ■b14, b15: System area
Sensing level	Read	Un\G12328+n × 30H (n: 0 to 255) 41th of 48 words	Indicates the value of a connected sensor. The value differs depending on the connected slave module. (Example: An analog value of 0 to 100% is indicated for an ON/OFF sensor.)

Number of word data points setting

■Number of word data points setting (Un\G31488)

This area stores the number of word data points.

When the number of word data points is set with the engineering tool, the setting is reflected when the CPU module is reset.

Setting value	Description
0	0 words (Word data is not used.)
1	2 words (1 input word/1 output word)
2	4 words (2 input words/2 output words)
⋮	
512	1024 words (512 input words/512 output words)

Word data start address setting

■Word data start address setting (Un\G31490)

This area stores the start address of the word data used in the word data start address setting function.

Setting value	Description
0	Word address 0
1	Word address 1
2	Word address 2
⋮	
511	Word address 511

Number of word data points per frame setting

■Number of word data points per frame setting (Un\G31492)

This area stores the number of word data points per frame of word transmission of AnyWireASLINK.

When the number of word data points is set with the engineering tool, the setting is reflected when the CPU module is reset.

Setting value	Description
0	0 words (Word data is not used.)
1	2 words (1 input word/1 output word)
2	4 words (2 input words/2 output words)
⋮	
5	32 words (16 input words/16 output words)

Number of word data cycles setting

■Number of word data cycles setting (Un\G31493)

This area stores the number of cycles for word transmission.

Setting value	Description
0	0 cycles
1	1 cycle
2	2 cycles
⋮	
512	512 cycles

Appendix 4 Processing Time

This section describes the processing time related to the transmission of AnyWireASLINK.

Transmission cycle time

In the transmission cycle time, I/O data of the RJ51AW12AL and all the slave modules is updated.

The following table lists the transmission cycle times of the RJ51AW12AL.

Bit transmission cycle time

The bit transmission cycle time is determined according to "Transmission points setting" and "Word data points setting per frame" in the Basic setting.

To use or not to use word data setting	Transmission points setting	Word data points setting per frame	Bit transmission cycle time
Not use	64 points (32 input points/32 output points)	—	2.4ms
	128 points (64 input points/64 output points)	—	3.6ms
	256 points (128 input points/128 output points)	—	6.0ms
	512 points (256 input points/256 output points)	—	10.7ms
Use	64 points (32 input points/32 output points)	2 words (1 input word/1 output word)	4.9ms
		4 words (2 input words/2 output words)	6.1ms
		8 words (4 input words/4 output words)	8.5ms
		16 words (8 input words/8 output words)	13.2ms
		32 words (16 input words/16 output words)	22.7ms
	128 points (64 input points/64 output points)	2 words (1 input word/1 output word)	6.1ms
		4 words (2 input words/2 output words)	7.3ms
		8 words (4 input words/4 output words)	9.7ms
		16 words (8 input words/8 output words)	14.4ms
		32 words (16 input words/16 output words)	23.9ms
	256 points (128 input points/128 output points)	2 words (1 input word/1 output word)	8.5ms
		4 words (2 input words/2 output words)	9.7ms
		8 words (4 input words/4 output words)	12.0ms
		16 words (8 input words/8 output words)	16.8ms
		32 words (16 input words/16 output words)	26.2ms
	512 points (256 input points/256 output points)	2 words (1 input word/1 output word)	13.2ms
		4 words (2 input words/2 output words)	14.4ms
		8 words (4 input words/4 output words)	16.8ms
		16 words (8 input words/8 output words)	21.5ms
		32 words (16 input words/16 output words)	31.0ms

Word transmission cycle time

The word transmission cycle time is determined according to "Transmission points setting", "Word data points setting", and "Word data points setting per frame" in the Basic setting.

■When "Transmission points setting" is set to 0 (when the bit transmission is not used)

Word data points setting	Word data points setting per frame	Word transmission cycle time
2 words (1 input word/1 output word)	2 words (1 input word/1 output word)	3.7ms
4 words (2 input words/2 output words)	2 words (1 input word/1 output word)	7.4ms
	4 words (2 input words/2 output words)	4.9ms
8 words (4 input words/4 output words)	2 words (1 input word/1 output word)	14.8ms
	4 words (2 input words/2 output words)	9.8ms
	8 words (4 input words/4 output words)	7.3ms
16 words (8 input words/8 output words)	2 words (1 input word/1 output word)	29.5ms
	4 words (2 input words/2 output words)	19.5ms
	8 words (4 input words/4 output words)	14.5ms
	16 words (8 input words/8 output words)	12.0ms
32 words (16 input words/16 output words)	2 words (1 input word/1 output word)	59.0ms
	4 words (2 input words/2 output words)	39.0ms
	8 words (4 input words/4 output words)	29.0ms
	16 words (8 input words/8 output words)	24.0ms
	32 words (16 input words/16 output words)	21.5ms
64 words (32 input words/32 output words)	2 words (1 input word/1 output word)	117.9ms
	4 words (2 input words/2 output words)	77.9ms
	8 words (4 input words/4 output words)	57.9ms
	16 words (8 input words/8 output words)	47.9ms
	32 words (16 input words/16 output words)	42.9ms
128 words (64 input words/64 output words)	2 words (1 input word/1 output word)	235.7ms
	4 words (2 input words/2 output words)	155.7ms
	8 words (4 input words/4 output words)	115.8ms
	16 words (8 input words/8 output words)	95.8ms
	32 words (16 input words/16 output words)	85.8ms
256 words (128 input words/128 output words)	2 words (1 input word/1 output word)	471.3ms
	4 words (2 input words/2 output words)	311.4ms
	8 words (4 input words/4 output words)	231.5ms
	16 words (8 input words/8 output words)	191.6ms
	32 words (16 input words/16 output words)	171.6ms
512 words (256 input words/256 output words)	2 words (1 input word/1 output word)	942.5ms
	4 words (2 input words/2 output words)	622.8ms
	8 words (4 input words/4 output words)	463.0ms
	16 words (8 input words/8 output words)	383.1ms
	32 words (16 input words/16 output words)	343.1ms
1024 words (512 input words/512 output words)	2 words (1 input word/1 output word)	1885.0ms
	4 words (2 input words/2 output words)	1245.6ms
	8 words (4 input words/4 output words)	925.9ms
	16 words (8 input words/8 output words)	766.1ms
	32 words (16 input words/16 output words)	686.2ms

■When "Transmission points setting" is set to 64

Word data points setting	Word data points setting per frame	Word transmission cycle time
2 words (1 input word/1 output word)	2 words (1 input word/1 output word)	4.9ms
4 words (2 input words/2 output words)	2 words (1 input word/1 output word)	9.8ms
	4 words (2 input words/2 output words)	6.1ms
8 words (4 input words/4 output words)	2 words (1 input word/1 output word)	19.5ms
	4 words (2 input words/2 output words)	12.1ms
	8 words (4 input words/4 output words)	8.5ms
16 words (8 input words/8 output words)	2 words (1 input word/1 output word)	39.0ms
	4 words (2 input words/2 output words)	24.2ms
	8 words (4 input words/4 output words)	16.9ms
	16 words (8 input words/8 output words)	13.2ms
32 words (16 input words/16 output words)	2 words (1 input word/1 output word)	77.9ms
	4 words (2 input words/2 output words)	48.4ms
	8 words (4 input words/4 output words)	33.7ms
	16 words (8 input words/8 output words)	26.4ms
	32 words (16 input words/16 output words)	22.7ms
64 words (32 input words/32 output words)	2 words (1 input word/1 output word)	155.7ms
	4 words (2 input words/2 output words)	96.8ms
	8 words (4 input words/4 output words)	67.4ms
	16 words (8 input words/8 output words)	52.7ms
	32 words (16 input words/16 output words)	45.3ms
128 words (64 input words/64 output words)	2 words (1 input word/1 output word)	311.4ms
	4 words (2 input words/2 output words)	193.6ms
	8 words (4 input words/4 output words)	134.7ms
	16 words (8 input words/8 output words)	105.3ms
	32 words (16 input words/16 output words)	90.6ms
256 words (128 input words/128 output words)	2 words (1 input word/1 output word)	622.8ms
	4 words (2 input words/2 output words)	387.2ms
	8 words (4 input words/4 output words)	269.4ms
	16 words (8 input words/8 output words)	210.5ms
	32 words (16 input words/16 output words)	181.1ms
512 words (256 input words/256 output words)	2 words (1 input word/1 output word)	1245.6ms
	4 words (2 input words/2 output words)	774.4ms
	8 words (4 input words/4 output words)	538.8ms
	16 words (8 input words/8 output words)	421.0ms
	32 words (16 input words/16 output words)	362.1ms
1024 words (512 input words/512 output words)	2 words (1 input word/1 output word)	2491.2ms
	4 words (2 input words/2 output words)	1548.7ms
	8 words (4 input words/4 output words)	1077.5ms
	16 words (8 input words/8 output words)	841.9ms
	32 words (16 input words/16 output words)	724.1ms

■When "Transmission points setting" is set to 128

Word data points setting	Word data points setting per frame	Word transmission cycle time
2 words (1 input word/1 output word)	2 words (1 input word/1 output word)	6.1ms
4 words (2 input words/2 output words)	2 words (1 input word/1 output word)	12.1ms
	4 words (2 input words/2 output words)	7.3ms
8 words (4 input words/4 output words)	2 words (1 input word/1 output word)	24.2ms
	4 words (2 input words/2 output words)	14.5ms
	8 words (4 input words/4 output words)	9.7ms
16 words (8 input words/8 output words)	2 words (1 input word/1 output word)	48.4ms
	4 words (2 input words/2 output words)	29.0ms
	8 words (4 input words/4 output words)	19.3ms
	16 words (8 input words/8 output words)	14.4ms
32 words (16 input words/16 output words)	2 words (1 input word/1 output word)	96.8ms
	4 words (2 input words/2 output words)	57.9ms
	8 words (4 input words/4 output words)	38.5ms
	16 words (8 input words/8 output words)	28.7ms
	32 words (16 input words/16 output words)	23.9ms
64 words (32 input words/32 output words)	2 words (1 input word/1 output word)	193.6ms
	4 words (2 input words/2 output words)	115.8ms
	8 words (4 input words/4 output words)	76.9ms
	16 words (8 input words/8 output words)	57.4ms
	32 words (16 input words/16 output words)	47.7ms
128 words (64 input words/64 output words)	2 words (1 input word/1 output word)	387.2ms
	4 words (2 input words/2 output words)	231.5ms
	8 words (4 input words/4 output words)	153.7ms
	16 words (8 input words/8 output words)	114.7ms
	32 words (16 input words/16 output words)	95.3ms
256 words (128 input words/128 output words)	2 words (1 input word/1 output word)	774.4ms
	4 words (2 input words/2 output words)	463.0ms
	8 words (4 input words/4 output words)	307.3ms
	16 words (8 input words/8 output words)	229.4ms
	32 words (16 input words/16 output words)	190.5ms
512 words (256 input words/256 output words)	2 words (1 input word/1 output word)	1548.7ms
	4 words (2 input words/2 output words)	925.9ms
	8 words (4 input words/4 output words)	614.5ms
	16 words (8 input words/8 output words)	458.8ms
	32 words (16 input words/16 output words)	381.0ms
1024 words (512 input words/512 output words)	2 words (1 input word/1 output word)	3097.4ms
	4 words (2 input words/2 output words)	1851.8ms
	8 words (4 input words/4 output words)	1229.0ms
	16 words (8 input words/8 output words)	917.6ms
	32 words (16 input words/16 output words)	762.0ms

■When "Transmission points setting" is set to 256

Word data points setting	Word data points setting per frame	Word transmission cycle time
2 words (1 input word/1 output word)	2 words (1 input word/1 output word)	8.5ms
4 words (2 input words/2 output words)	2 words (1 input word/1 output word)	16.9ms
	4 words (2 input words/2 output words)	9.7ms
8 words (4 input words/4 output words)	2 words (1 input word/1 output word)	33.7ms
	4 words (2 input words/2 output words)	19.3ms
	8 words (4 input words/4 output words)	12.0ms
16 words (8 input words/8 output words)	2 words (1 input word/1 output word)	67.4ms
	4 words (2 input words/2 output words)	38.5ms
	8 words (4 input words/4 output words)	24.0ms
	16 words (8 input words/8 output words)	16.8ms
32 words (16 input words/16 output words)	2 words (1 input word/1 output word)	134.7ms
	4 words (2 input words/2 output words)	76.9ms
	8 words (4 input words/4 output words)	47.9ms
	16 words (8 input words/8 output words)	33.5ms
	32 words (16 input words/16 output words)	26.2ms
64 words (32 input words/32 output words)	2 words (1 input word/1 output word)	269.4ms
	4 words (2 input words/2 output words)	153.7ms
	8 words (4 input words/4 output words)	95.8ms
	16 words (8 input words/8 output words)	66.9ms
	32 words (16 input words/16 output words)	52.4ms
128 words (64 input words/64 output words)	2 words (1 input word/1 output word)	538.8ms
	4 words (2 input words/2 output words)	307.3ms
	8 words (4 input words/4 output words)	191.6ms
	16 words (8 input words/8 output words)	133.7ms
	32 words (16 input words/16 output words)	104.8ms
256 words (128 input words/128 output words)	2 words (1 input word/1 output word)	1077.5ms
	4 words (2 input words/2 output words)	614.5ms
	8 words (4 input words/4 output words)	383.1ms
	16 words (8 input words/8 output words)	267.3ms
	32 words (16 input words/16 output words)	209.5ms
512 words (256 input words/256 output words)	2 words (1 input word/1 output word)	2154.9ms
	4 words (2 input words/2 output words)	1229.0ms
	8 words (4 input words/4 output words)	766.1ms
	16 words (8 input words/8 output words)	534.6ms
	32 words (16 input words/16 output words)	418.9ms
1024 words (512 input words/512 output words)	2 words (1 input word/1 output word)	4309.8ms
	4 words (2 input words/2 output words)	2458.0ms
	8 words (4 input words/4 output words)	1532.1ms
	16 words (8 input words/8 output words)	1069.2ms
	32 words (16 input words/16 output words)	837.7ms

■When "Transmission points setting" is set to 512

Word data points setting	Word data points setting per frame	Word transmission cycle time
2 words (1 input word/1 output word)	2 words (1 input word/1 output word)	13.2ms
4 words (2 input words/2 output words)	2 words (1 input word/1 output word)	26.4ms
	4 words (2 input words/2 output words)	14.4ms
8 words (4 input words/4 output words)	2 words (1 input word/1 output word)	52.7ms
	4 words (2 input words/2 output words)	28.7ms
	8 words (4 input words/4 output words)	16.8ms
16 words (8 input words/8 output words)	2 words (1 input word/1 output word)	105.3ms
	4 words (2 input words/2 output words)	57.4ms
	8 words (4 input words/4 output words)	33.5ms
	16 words (8 input words/8 output words)	21.5ms
32 words (16 input words/16 output words)	2 words (1 input word/1 output word)	210.5ms
	4 words (2 input words/2 output words)	114.7ms
	8 words (4 input words/4 output words)	66.9ms
	16 words (8 input words/8 output words)	42.9ms
	32 words (16 input words/16 output words)	31.0ms
64 words (32 input words/32 output words)	2 words (1 input word/1 output word)	421.0ms
	4 words (2 input words/2 output words)	229.4ms
	8 words (4 input words/4 output words)	133.7ms
	16 words (8 input words/8 output words)	85.8ms
	32 words (16 input words/16 output words)	61.9ms
128 words (64 input words/64 output words)	2 words (1 input word/1 output word)	841.9ms
	4 words (2 input words/2 output words)	458.8ms
	8 words (4 input words/4 output words)	267.3ms
	16 words (8 input words/8 output words)	171.6ms
	32 words (16 input words/16 output words)	123.7ms
256 words (128 input words/128 output words)	2 words (1 input word/1 output word)	1683.7ms
	4 words (2 input words/2 output words)	917.6ms
	8 words (4 input words/4 output words)	534.6ms
	16 words (8 input words/8 output words)	343.1ms
	32 words (16 input words/16 output words)	247.4ms
512 words (256 input words/256 output words)	2 words (1 input word/1 output word)	3367.3ms
	4 words (2 input words/2 output words)	1835.2ms
	8 words (4 input words/4 output words)	1069.2ms
	16 words (8 input words/8 output words)	686.2ms
	32 words (16 input words/16 output words)	494.7ms
1024 words (512 input words/512 output words)	2 words (1 input word/1 output word)	6734.6ms
	4 words (2 input words/2 output words)	3670.4ms
	8 words (4 input words/4 output words)	2138.4ms
	16 words (8 input words/8 output words)	1372.3ms
	32 words (16 input words/16 output words)	989.3ms

Transmission cycle time formula

The transmission cycle times can be calculated using the following formulas.

■Bit transmission cycle time formula

$((\text{Number of bit data points} \div 2) + 67.5 + (\text{Number of word data points per frame} \times 32)) \times 37\mu\text{s}$

■Word transmission cycle time formula

$((\text{Number of bit points} \div 2) + 67.5 + (\text{Number of word data points per frame} \times 32)) \times \text{Number of word cycles} \times 37\mu\text{s}$

Point

Because the number of word cycles is automatically set, calculate the transmission cycle time using the number of word cycles stored in 'Number of word cycles setting' (Un\G31493) when the word data start address is set to a value other than 0.

Bit data update timing

Input

Unless the RJ51AW12AL receives the same data twice successively, data in the input area is not updated.

A minimum of one-transmission cycle time and a maximum of two-transmission cycle time are required as data response time.

Therefore, when input data is shorter than two-transmission cycle time, the input data may not be captured depending on the timing.

To ensure the response, provide an input signal that is longer than two-transmission cycle time.

■Case of minimum data response time

If no change is detected in input data between two sampling timings, communication in one-transmission cycle time is possible.

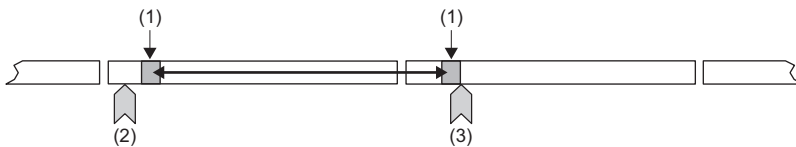

- (1) Sampling timing
- (2) Change of the input data
- (3) Update of the input data

■Case of maximum data response time

The input data is changed after a sampling, and thus the next sampling will be the first data reception. Time equivalent to two-transmission cycle time is required.

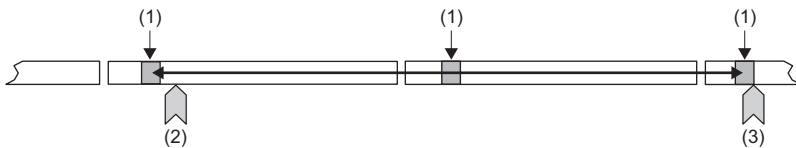

- (1) Sampling timing
- (2) Change of the input data
- (3) Update of the input data

Output

As the double verification of the bit data is executed on the slave module side, the time required is the same as that for input, namely a minimum of one-transmission cycle time and a maximum of two-transmission cycle time.

Update timing of word data

Input

The RJ51AW12AL receives the main data and the verification data in the same frame, and therefore the word input data will be sampled with the response delay time of one-transmission cycle time or shorter.

■Case of minimum data response time

If the word data has no abnormalities, the input data is updated in one-transmission cycle time or shorter.

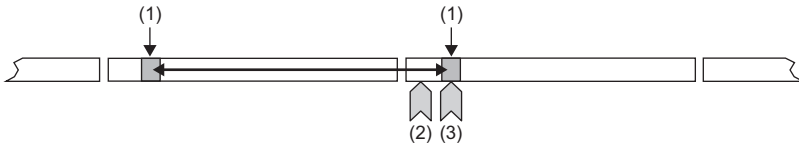

- (1) Sampling timing
- (2) Change of the input data
- (3) Update of the input data

■Case of maximum data response time

As with the minimum case, the input data is updated in one-transmission cycle time or shorter.

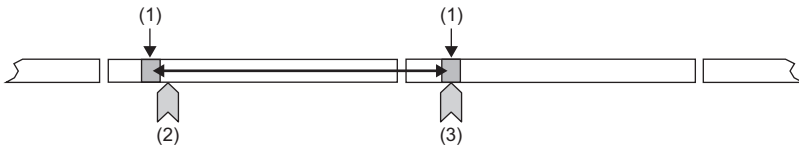

- (1) Sampling timing
- (2) Change of the input data
- (3) Update of the input data

Response delay time

The following shows the response delay time of input and output.

Input response delay time

The figure below shows the time from a signal input to the slave module to turning on or off of a device of the CPU module. The input response delay time is the total of ❶ to ❺ in the following figure.

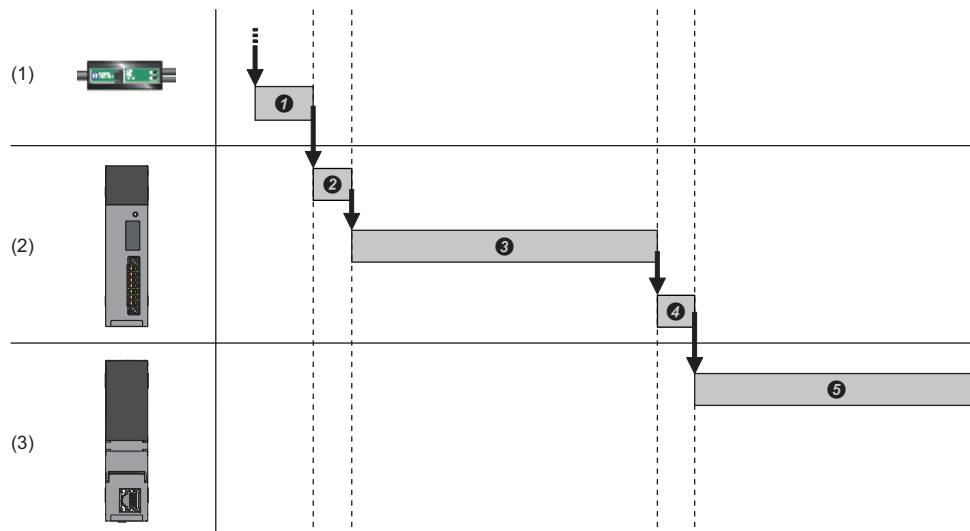

- (1) Slave module
- (2) AnyWireASLINK
- (3) CPU module

No.	Description	Required time
❶	Input response time on the slave module	Refer to the manual for the slave module connected to the system or the device connected to the slave module.
❷	Processing time on the slave module	Approx. 0.2ms (Differs depending on the slave module.)
❸	Transmission time	<ul style="list-style-type: none"> • Bit data: Bit transmission cycle time × 2 • Word data: Word transmission cycle time The transmission cycle time varies depending on the specified number of bit data points and the specified number of word data points. (Page 111 Transmission cycle time)
❹	Processing time on the RJ51AW12AL	0.6ms
❺	Processing time on the programmable controller	<ul style="list-style-type: none"> • Bit data: Sequence scan time × 2 • Word data: Sequence scan time × Set value of the number of word data cycles

Output response delay time

The figure below shows the time from turning on or off of a device of the CPU module to turning on or off of an output of a slave module.

The output response delay time is the total of ① to ⑤ in the following figure.

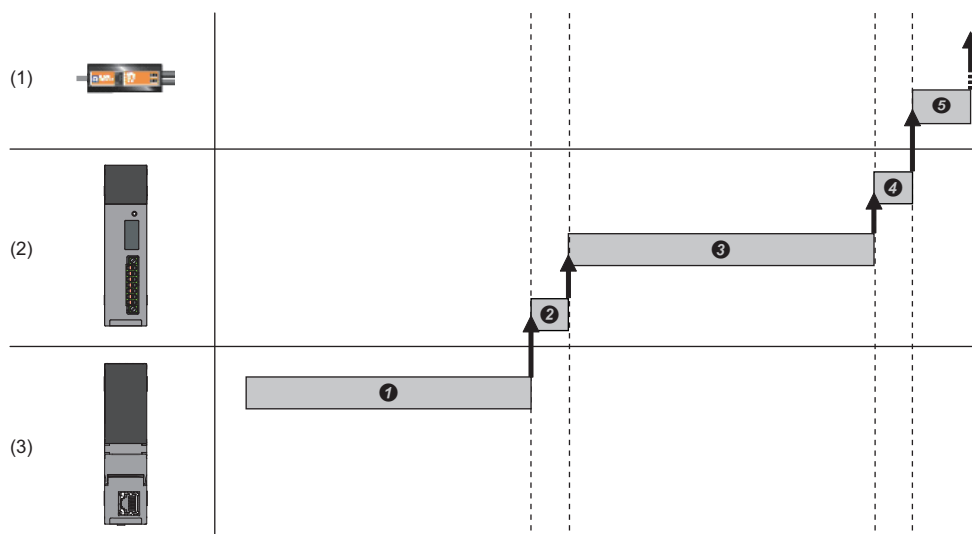

- (1) Slave module
- (2) AnyWireASLINK
- (3) CPU module

No.	Description	Required time
①	Processing time on the programmable controller	Sequence scan time
②	Processing time on the RJ51AW12AL	0.6ms
③	Transmission time	<ul style="list-style-type: none"> • Bit data: Bit transmission cycle time × 2 • Word data: Word transmission cycle time The transmission cycle time varies depending on the specified number of bit data points and the specified number of word data points. (Page 111 Transmission cycle time)
④	Processing time on the slave module	Approx. 0.04ms (Differs depending on the slave module.)
⑤	Output response time on the slave module	Refer to the manual for the slave module connected to the system or the device connected to the slave module.

A

Parameter access response time

The parameters of AnyWireASLINK provide monitoring information of slave modules or the entire system and setting information of the slave modules.

Parameter data is synchronized between the buffer memory of the RJ51AW12AL and slave modules at a cycle different from that of the I/O data.

Use the following calculation formulas to obtain the parameter access response time.

Item	Calculation formula
Update interval time of an automatically updated parameter*1	Number of AnyWireASLINK connection IDs × Transmission cycle time × 3
Time required for reading parameters	Number of target IDs × Transmission cycle time × 27*2
Time required for writing parameters	Number of target IDs × Transmission cycle time × 39*2

*1 The parameters to be accessed are the status details and the sensing level.

*2 The number of target IDs is as follows.

During parameter access: 1

During parameter batch read: The number of IDs registered at the time of automatic address detection

During parameter batch write: The number of IDs registered at the time of automatic address detection

Appendix 5 When Connecting the Module to a Remote Head Module

This section describes the restrictions and communication example for when connecting the RJ51AW12AL to a remote head module.

Restricted functions and specifications

Function

As for the iQSS functions (such as backup/restoration and automatic reading of system configuration), when the RJ51AW12AL is mounted on the remote head module, only the functions supported by the remote head module are usable. For details, refer to the following.

📖 iQ Sensor Solution Reference Manual

Module parameter

As for the iQSS functions (such as backup/restoration and automatic reading of system configuration), when the RJ51AW12AL is mounted on the remote head module, only the functions supported by the remote head module are usable. For details, refer to the following.

📖 iQ Sensor Solution Reference Manual

Communication example

This section describes the communication example for when connecting the RJ51AW12AL to a remote head module.

System configuration

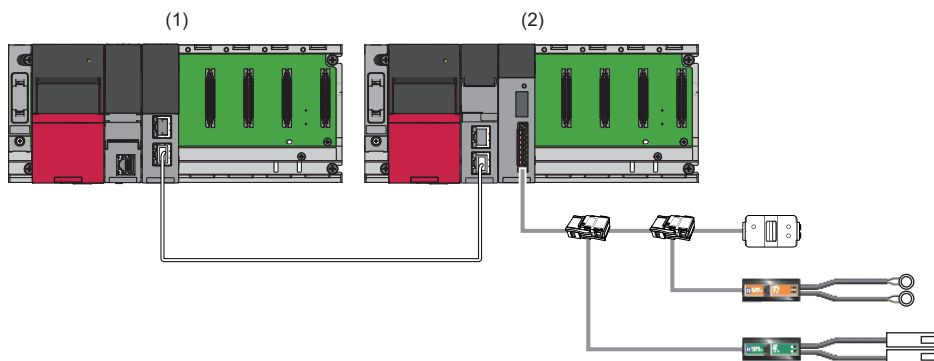

(1) Master station (network No.1, station No.0)

- Power supply module: R61P
- CPU module: R04CPU
- CC-Link IE Field Network master/local module: RJ71GF11-T2 (start I/O number: 0000H to 001FH)

(2) Intelligent device station (network No.1, station No.1)

- Power supply module: R61P
- Remote head module: RJ72GF15-T2
- AnyWireASLINK master module: RJ51AW12AL (start I/O number: 0000H to 001FH)
- Output slave module (2-point output ASLINKER): Address 0
- Input slave module (2-point input ASLINKER): Address 0
- Terminating unit
- LED
- Sensor switch

Link device assignment

This section describes the RX/RX assignment of program example.

■RX/RX assignment

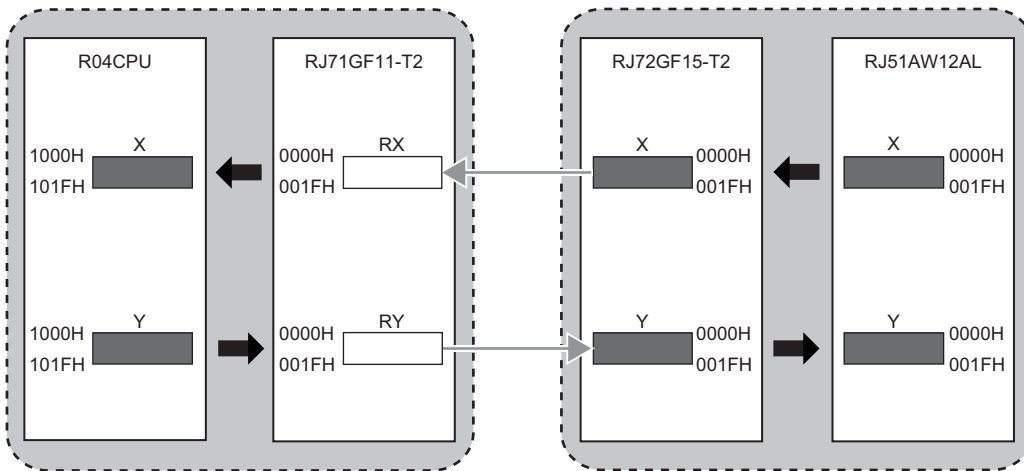

The following shows the correspondence between CPU module devices and I/O signals of the RJ51AW12AL.

CPU module	RJ51AW12AL	
Device	I/O signals	Device
X1000	Module READY	X0
X1001	DP/DN short error	X1
X1002	24V/DP short error	X2
X1003	Transmission cable voltage drop error	X3
X1004	DP/DN disconnection error	X4

Setting in the master station

Connect the engineering tool to the CPU module on the master station and set parameters.

1. Set the CPU module as follows.

 [Project] ⇒ [New]

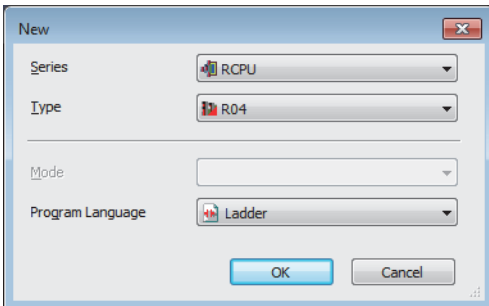

2. Click the [OK] button to add the module labels of the CPU module.

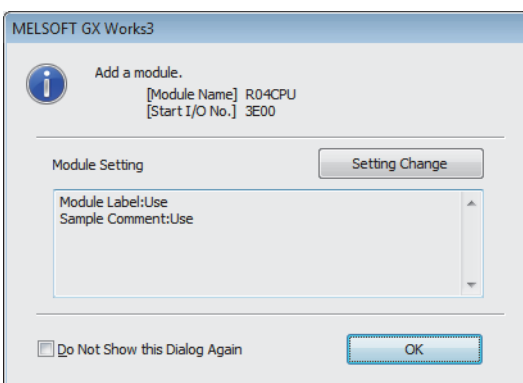

3. Set the CC-Link IE Field Network master/local module as follows.

 [Navigation window] ⇒ [Parameter] ⇒ [Module Information] ⇒ Right click ⇒ [Add New Module]

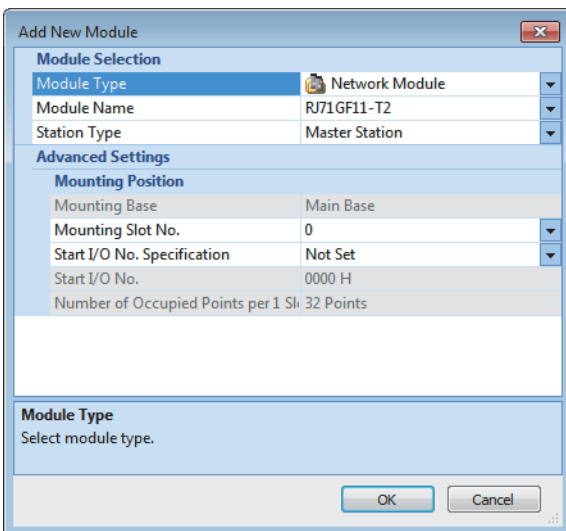

A

- Click the [OK] button to add the module labels of the CC-Link IE Field Network master/local module.

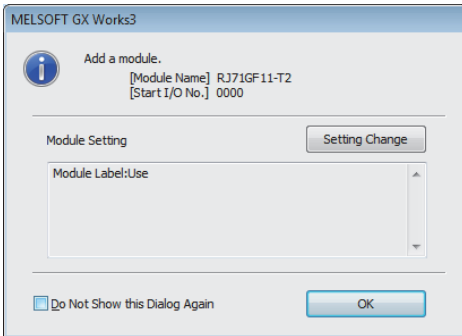

- Set the items in "Required Settings" as follows.

[Navigation window] ⇒ [Parameter] ⇒ [Module Information] ⇒ [RJ71GF11-T2] ⇒ [Required Settings]

Item	Setting
Station Type	
Station Type	Master Station
Network Number	
Network Number	1
Station Number	
Setting Method	Parameter Editor
Station No.	0
Parameter Setting Method	
Setting Method of Basic/Application Settings	Parameter Editor



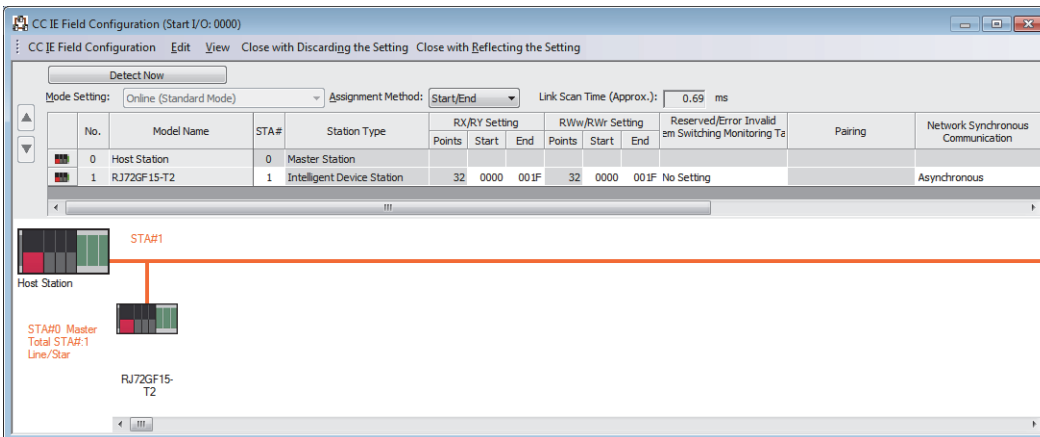

- Set the network configuration as follows.

[Navigation window] ⇒ [Parameter] ⇒ [Module Information] ⇒ [RJ71GF11-T2] ⇒ [Basic Settings] ⇒ [Network Configuration Settings]



7. Set the refresh settings as follows.

 [Navigation window] ⇒ [Parameter] ⇒ [Module Information] ⇒ [RJ71GF11-T2] ⇒ [Basic Settings] ⇒ [Refresh Setting]

No.	Link Side					CPU Side				
	Device Name	Points	Start	End		Target	Device Name	Points	Start	End
-	SB	512	00000	001FF		Module Label				
-	SW	512	00000	001FF		Module Label				
1	RX	32	00000	0001F		Specify Device	X	32	01000	0101F
2	RY	32	00000	0001F		Specify Device	Y	32	01000	0101F

8. Write the set parameters to the CPU module on the master station. Then, reset the CPU module or power off and on the system.

 [Online] ⇒ [Write to PLC]

Point 

In this example, default values are used for parameters that are not shown above. For the parameters, refer to the following.

 MELSEC iQ-R CC-Link IE Field Network User's Manual (Application)

Setting in the intelligent device station

Connect the engineering tool to the remote head module on the intelligent device station and set the parameters.

1. Set the remote head module as follows.

[Project] ⇒ [New]

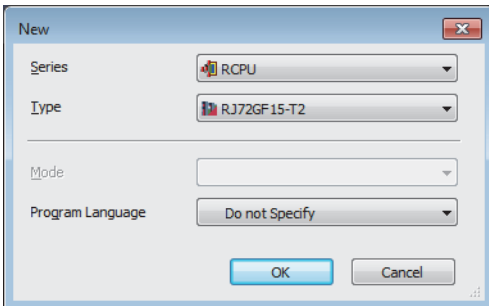

2. Set the items in "Network Required Setting" of "CPU Parameter" as follows.

[Navigation window] ⇒ [Parameter] ⇒ [RJ72GF15-T2] ⇒ [CPU Parameter] ⇒ [Network Required Setting]

Setting Item	
Item	Setting
Network Number	
Network Number	1
Station Number	
Station No.	1

3. Set the RJ51AW12AL as follows.

[Navigation window] ⇒ [Parameter] ⇒ [Module Information] ⇒ Right click ⇒ [Add New Module]

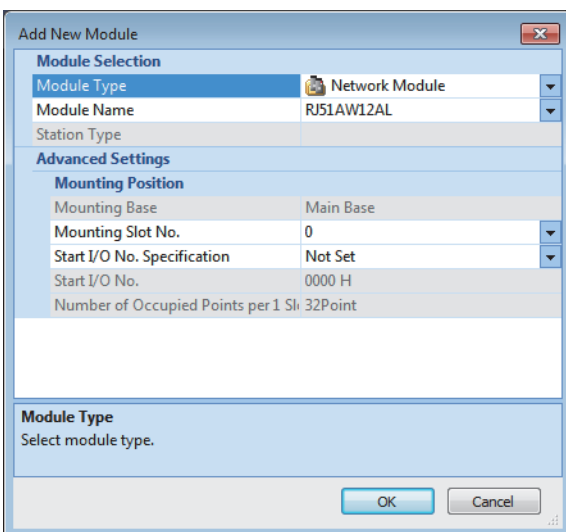

4. Click the [OK] button.

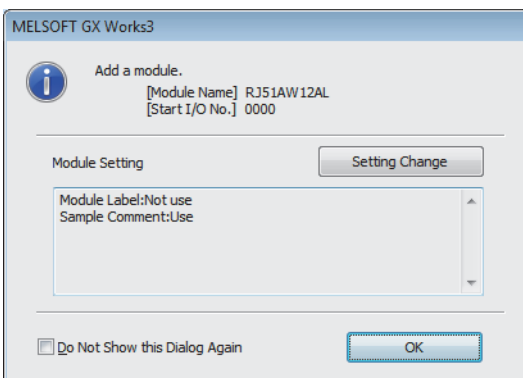

5. Set the items in "Basic setting" of "Module Parameter" as follows.

[Navigation window] ⇒ [Parameter] ⇒ [Module Information] ⇒ [RJ51AW12AL] ⇒ [Module Parameter] ⇒ [Basic setting]

Item	Setting Value
Transmission points	
Transmission points setting	3: 512 points(256 input points/256 output points)
Startup operating mode	
Startup operating mode setting	0: Without slave information acquisition
Double verification	
Double verification setting	0: All points,double verification of a bit
Error status automatic recovery	
Error status automatic recovery mode setting	0: No error status automatic recovery
Output data hold/clear setting when error occurs	
Output data hold/clear setting when error occurs	0: CLEAR
Word input data hold/clear setting when error occurs	
Word input data hold/clear setting when error occurs	0: CLEAR
Easy replacement enable/disable setting for one slave mod	
Easy replacement enable/disable setting for one slave mod	0: Enable
Word data points setting	
To use or not to use word data setting	0: Not use
Word data points setting	0: word data (no word data)
Word data start address	0
Word data points setting per frame	0: word data (no word data)

6. Write the set parameters to the remote head module on the intelligent device station. Then, reset the remote head module or power off and on the system.

[Online] ⇒ [Write to PLC]

Point

In this example, default values are used for parameters that are not shown above. For the parameters, refer to the following.

- MELSEC iQ-R CC-Link IE Field Network Remote Head Module User's Manual (Application)
- Page 48 PARAMETER SETTINGS

Settings in the slave modules

Write addresses to slave modules and register them with the RJ51AW12AL.

■Address setting

Write addresses to slave modules with an address writer.

- Output ASLINKER: Address 0 (ID: 0000H)
- Input ASLINKER: Address 0 (ID: 0200H)

■Automatic address detection

Keep pressing the SET switch on the RJ51AW12AL until the SET LED turns on.

When the SET LED flashes and then turns off, it indicates that the registration of IDs (addresses) has been completed.

Checking the system status

■Checking CC-Link IE Field Network

After setting parameters for the master station and intelligent device station, perform the CC-Link IE Field Network diagnostics of the engineering tool to check whether data link can normally be performed between the master station and intelligent device station.

1. Connect the engineering tool to the CPU module on the master station.
2. Start the CC-Link IE Field Network diagnostics.

 [Diagnostics] ⇒ [CC-Link IE Field Diagnostics]

For information on the CC-Link IE Field Network diagnostics from the master station, refer to the following.

 MELSEC iQ-R CC-Link IE Field Network User's Manual (Application)

■Checking AnyWireASLINK

Check whether the RJ51AW12AL can communicate with the slave modules normally.

The following LED statuses indicate that the communication is established normally.

- LED of the RJ51AW12AL

LED	Status
RUN	On
ERR	Off
LINK	Flashing
SET	Off
ALM	Off

- LED of the ASLINKER

LED	Status
LINK LED	Flashing
ALM LED	Off

Program example

This program uses the module labels of the CC-Link IE Field Network master/local module.

Write the program to the CPU module on the master station.

Classification	Label name	Description	Device	
Module label	GF11_1.bSts_DataLinkError	Data link error status of own station	SB0049	
	GF11_1.bnSts_DataLinkError_Station[1]	Data link status of each station (station No.1)	SW00B0.0	
Label to be defined	Define global labels as shown below:			
	Label Name	Data Type	Class	Assign (Device/Label)
	bModuleREADY	Bit	VAR_GLOBAL	X1000
	bDP_DNShortError	Bit	VAR_GLOBAL	X1001
	b24V_DPShortError	Bit	VAR_GLOBAL	X1002
	bTransmissionCableVoltageDdropError	Bit	VAR_GLOBAL	X1003
	bDP_DNDisconnectionError	Bit	VAR_GLOBAL	X1004
	bConnectFormationFlag	Bit	VAR_GLOBAL	M0
	bStartDirection	Bit	VAR_GLOBAL	M1
	bREMT0InstructionStartDirection	Bit	VAR_GLOBAL	M155
	bREMFRIInstructionStartDirection	Bit	VAR_GLOBAL	M156
	bREMT0InstructionCompleteStatusDevice	Bit(0..1)	VAR_GLOBAL	M10
	bREMFRIInstructionCompleteStatusDevice	Bit(0..1)	VAR_GLOBAL	M12
	wInputData	Word [Unsigned]/Bit String [16-bit]	VAR_GLOBAL	K4X100
	wOutputData	Word [Unsigned]/Bit String [16-bit]	VAR_GLOBAL	K4Y100
	wReadData	Word [Unsigned]/Bit String [16-bit]	VAR_GLOBAL	D500
	wWriteData	Word [Unsigned]/Bit String [16-bit]	VAR_GLOBAL	D100
	bREMFRIInstructionNormalComplete	Bit	VAR_GLOBAL	M20

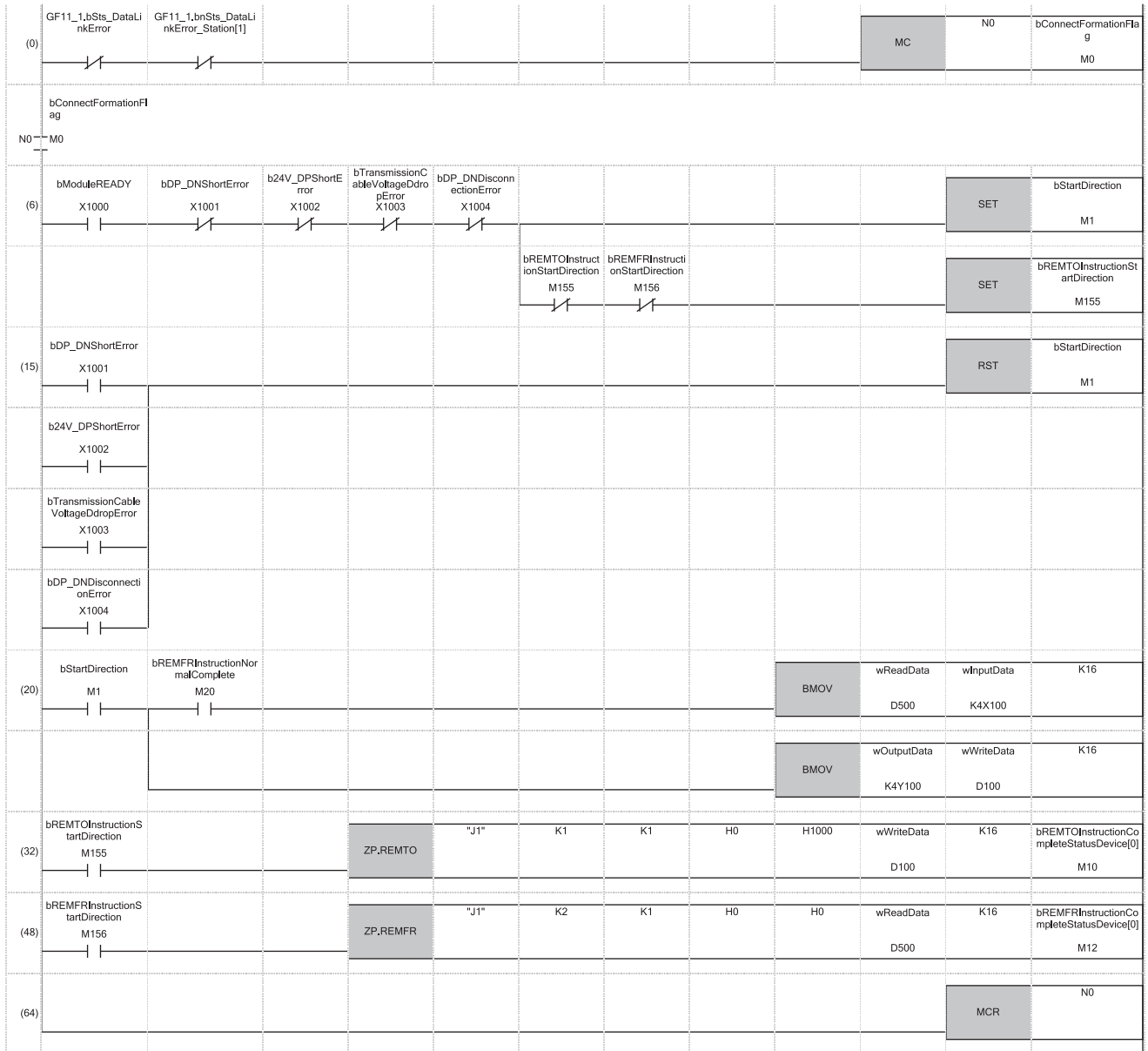

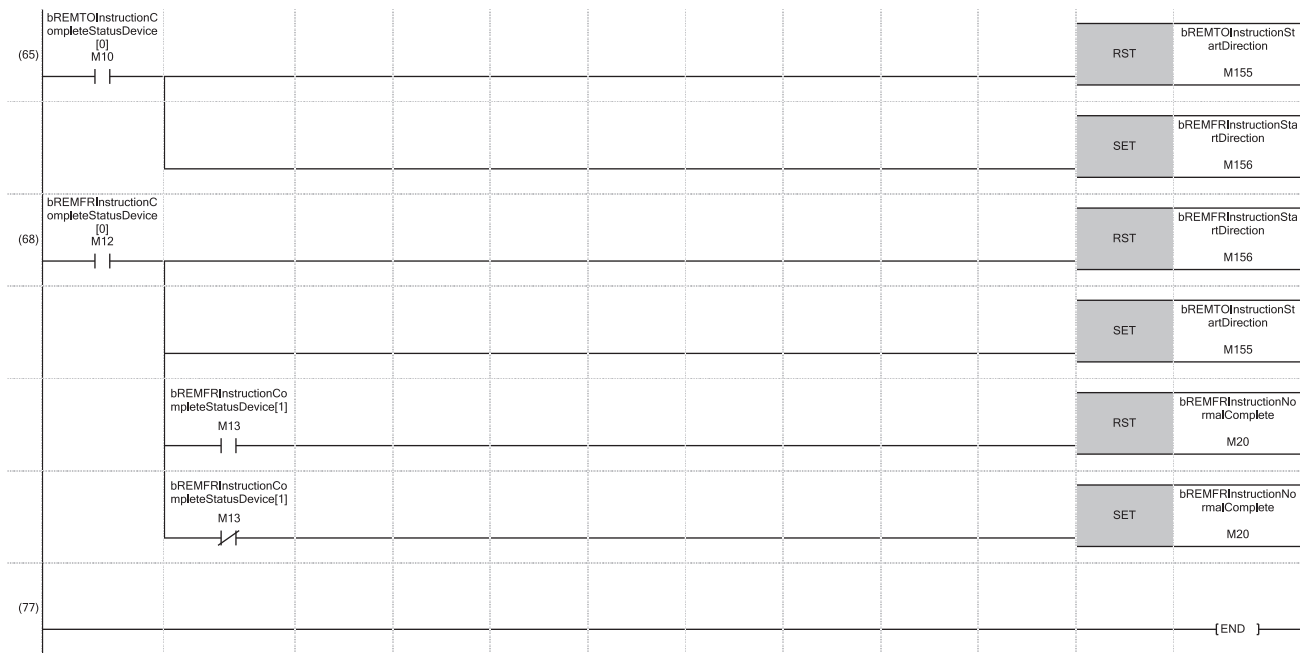

(0) Check the data link status of the remote head module (station No.1).

(20) When 'bStartDirection' (M1) is turned on, the data stored in 16-point areas starting from 'ReadData' (D500) are transferred to 'InputData' (K4X100). In addition, the data stored in 16-point areas in 'OutputData' (K4Y100) are transferred to 'WriteData' (D100).

(32) Write the data stored in 16-point areas starting from 'wWriteData' (D100) to buffer memory areas of the RJ51AW12AL (U0\G4096 to U0\G4111) using the ZP.REMTO instruction.

(48) Read the data stored in 16-point areas in the buffer memory areas of the RJ51AW12AL (U0\G0 to U0\G15) to 'ReadData' (D500) using the ZP.REMFR instruction.

(65) Perform the processing at end of the ZP.REMTO instruction.

(68) Perform the processing at end of the ZP.REMFR instruction.

Appendix 6 Added or Changed Functions

This section describes added or changed functions of the RJ51AW12AL.

Addition or change	First two digits of the production information
Word transmission was made available.	"03" or later
The word data start address setting function was added.	"03" or later
Easy replacement function for one slave module was added.	"03" or later
The AnyWireASLINK version compatibility inspection function was added.	"03" or later
The parameter access with handshake was made available for the slave module parameter read/write.	"03" or later

INDEX

0 to 9

- 24V/DP short error 89
- 48-word structure (details on parameter storage area) 108

A

- Address 14
- Address and ID 55
- Address setting 54
- Address setting example 55
- Adjustment mode executing flag 91
- Alarm ID information storage area 103
- AnyWireASLINK 14
- AnyWireASLINK parameter 109
- AnyWireASLINK version compatibility inspection command 93
- AnyWireASLINK version compatibility inspection error 90
- AnyWireASLINK version compatibility inspection executing flag 91
- Automatic address detection 58
- Automatic address detection command 93
- Automatic address detection flag 92

B

- Backup/Restore unsupported error 90
- Bit transmission cycle time 111
- Buffer memory 94

C

- Change ID specification 104
- Connected module ID information storage area 102

D

- Device 14
- Device parameter 109
- DP/DN disconnection error 89
- DP/DN short error 89

E

- Engineering tool 14
- Error flag clear command 93
- Error ID information bit area 99
- Error ID information storage area 98
- Event code for sub information area 106

I

- ID 14
- Input information area 96
- Input response delay time 120
- Input signal 87
- Intelligent function module 14
- Interlock program of automatic address detection 62

L

- Label 14
- Latest error code storage area 103
- Latest error ID storage area 103

M

- Module ID 109
- Module label 14
- Module READY 89

N

- Number of the alarm IDs 102
- Number of the connected modules 102
- Number of the error IDs 98
- Number of the IDs of the connected modules 102
- Number of word data cycles setting 110
- Number of word data points per frame setting 110
- Number of word data points setting 110

O

- One slave module changing flag 92
- Output information area 97
- Output response delay time 121
- Output signal 88
- Overlap address inspection command 93
- Overlap address inspection flag 92

P

- Parameter access completion flag 92
- Parameter access error 92
- Parameter access flag (with handshake) 90
- Parameter access request command for the slave module 93
- Parameter access setting 104
- Parameter access target module ID specification 104
- Parameter accessing flag (with handshake) 90
- Parameter batch read command for the slave module 93
- Parameter batch write command for the slave module 93
- Parameter storage area 107
- Parameter storage location memory number 105

R

- Reading the sensing level information 71
- Reading the status details (I/O disconnection) 69

S

- Sensing level 109
- Slave module 15
- Slave module alarm signal 91
- Slave module replacement completion flag 92
- Status details 109

T

Terminating unit	14
Transmission cable voltage drop error	89
Transmission cycle time	111

W

Word data start address setting	110
Word transmission cycle time	112



REVISIONS

*The manual number is given on the bottom left of the back cover.

Revision date	*Manual number	Description
June 2016	SH(NA)-081585ENG-A	First edition
November 2016	SH(NA)-081585ENG-B	■Added function Automatic reading of system configuration that supports iQ Sensor Solution ■Added or modified parts SAFETY PRECAUTIONS, RELEVANT MANUALS, Section 1.3, Section 1.5, Section 2.7
April 2019	SH(NA)-081585ENG-C	■Added functions Word transmission, word data start address setting function, easy replacement for one slave module, AnyWireASLINK version compatibility inspection function ■Added or modified parts RELEVANT MANUALS, TERMS, Section 1.1, Section 1.2, Section 1.3, Section 1.4, Section 1.5, Section 1.6, Section 1.7, Section 1.8, Section 1.9, Section 1.12, Section 1.13, Section 1.14, Section 1.15, Section 2.2, Section 2.3, Section 2.6, Section 2.7, Section 3.3, Section 4.1, Section 4.3, Section 4.4, Section 4.5, Appendix 2, Appendix 3, Appendix 4, Appendix 5, Appendix 6

Japanese manual number: SH-081583-C

This manual confers no industrial property rights of any other kind, nor does it confer any patent licenses. Mitsubishi Electric Corporation cannot be held responsible for any problems involving industrial property rights which may occur as a result of using the contents noted in this manual.

© 2016 MITSUBISHI ELECTRIC CORPORATION

WARRANTY

Please confirm the following product warranty details before using this product.

1. Gratis Warranty Term and Gratis Warranty Range

If any faults or defects (hereinafter "Failure") found to be the responsibility of Mitsubishi occurs during use of the product within the gratis warranty term, the product shall be repaired at no cost via the sales representative or Mitsubishi Service Company.

However, if repairs are required onsite at domestic or overseas location, expenses to send an engineer will be solely at the customer's discretion. Mitsubishi shall not be held responsible for any re-commissioning, maintenance, or testing on-site that involves replacement of the failed module.

[Gratis Warranty Term]

The gratis warranty term of the product shall be for one year after the date of purchase or delivery to a designated place. Note that after manufacture and shipment from Mitsubishi, the maximum distribution period shall be six (6) months, and the longest gratis warranty term after manufacturing shall be eighteen (18) months. The gratis warranty term of repair parts shall not exceed the gratis warranty term before repairs.

[Gratis Warranty Range]

- (1) The range shall be limited to normal use within the usage state, usage methods and usage environment, etc., which follow the conditions and precautions, etc., given in the instruction manual, user's manual and caution labels on the product.
- (2) Even within the gratis warranty term, repairs shall be charged for in the following cases.
 1. Failure occurring from inappropriate storage or handling, carelessness or negligence by the user. Failure caused by the user's hardware or software design.
 2. Failure caused by unapproved modifications, etc., to the product by the user.
 3. When the Mitsubishi product is assembled into a user's device, Failure that could have been avoided if functions or structures, judged as necessary in the legal safety measures the user's device is subject to or as necessary by industry standards, had been provided.
 4. Failure that could have been avoided if consumable parts (battery, backlight, fuse, etc.) designated in the instruction manual had been correctly serviced or replaced.
 5. Failure caused by external irresistible forces such as fires or abnormal voltages, and Failure caused by force majeure such as earthquakes, lightning, wind and water damage.
 6. Failure caused by reasons unpredictable by scientific technology standards at time of shipment from Mitsubishi.
 7. Any other failure found not to be the responsibility of Mitsubishi or that admitted not to be so by the user.

2. Onerous repair term after discontinuation of production

- (1) Mitsubishi shall accept onerous product repairs for one year after production of the product is discontinued. Discontinuation of production shall be notified with Mitsubishi Technical Bulletins, etc.
- (2) Product supply (including repair parts) is not available after production is discontinued.

3. Overseas service

Overseas, repairs shall be accepted by Mitsubishi's local overseas FA Center. Note that the repair conditions at each FA Center may differ.

4. Exclusion of loss in opportunity and secondary loss from warranty liability

Regardless of the gratis warranty term, Mitsubishi shall not be liable for compensation to:

- (1) Damages caused by any cause found not to be the responsibility of Mitsubishi.
- (2) Loss in opportunity, lost profits incurred to the user by Failures of Mitsubishi products.
- (3) Special damages and secondary damages whether foreseeable or not, compensation for accidents, and compensation for damages to products other than Mitsubishi products.
- (4) Replacement by the user, maintenance of on-site equipment, start-up test run and other tasks.

5. Changes in product specifications

The specifications given in the catalogs, manuals or technical documents are subject to change without prior notice.

TRADEMARKS

Anywire and AnyWireASLINK are either registered trademarks or trademarks of Anywire Corporation.

The company names, system names and product names mentioned in this manual are either registered trademarks or trademarks of their respective companies.

In some cases, trademark symbols such as [™] or [®] are not specified in this manual.

Anywire Anywire Corporation www.anywire.jp

SH(NA)-081585ENG-C(1904)MEE

MODEL: R-ANYWIRE-U-OU-E

MODEL CODE: 13JX48

MITSUBISHI ELECTRIC CORPORATION

HEAD OFFICE : TOKYO BUILDING, 2-7-3 MARUNOUCHI, CHIYODA-KU, TOKYO 100-8310, JAPAN
NAGOYA WORKS : 1-14, YADA-MINAMI 5-CHOME, HIGASHI-KU, NAGOYA, JAPAN

When exported from Japan, this manual does not require application to the Ministry of Economy, Trade and Industry for service transaction permission.

Specifications subject to change without notice.